



Design out the box

Time 50-60 mins approx

Level of difficulty 

Lesson Objectives...

- To understand the basic skills used in One Point Perspective.
- To understand the advantages of using One Point Perspective
- To be able to successfully use One Point Perspective independently to complete a range of tutorials in 3D
- To develop advanced skills and problem solving skills when using One Point Perspective to Create everyday objects in 3D

Lesson Outcomes...

By the end of this tutorial you will be able to...

- Draw vertical Lines
- Draw Horizontal Lines
- Use a vanishing point(s).
- Use the crating technique to draw 3D objects and add detail
- Shape and form your designs
- Colour and render your designs

Skills to be used in this project...

Basic Skills	New and Higher Skills
Light line pencil skills	Using fine Line Pen
2D drawing	3D drawing
Using vanishing points	Adding Independent details
Using fine line pens	Extending tutorial
Completing tutorial	Using crating technique
Adding colour	Rendering using textures and materials

Basic skills are those required to do very basic drawings and are detailed as part of this presentation.

New and higher skills may be new to the novice and are the focus for learning in this presentation.

Draw a border

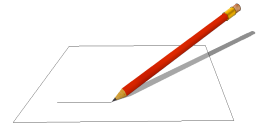

Hints: Sharp Pencil
Light Lines

Draw two light lines from corner to corner

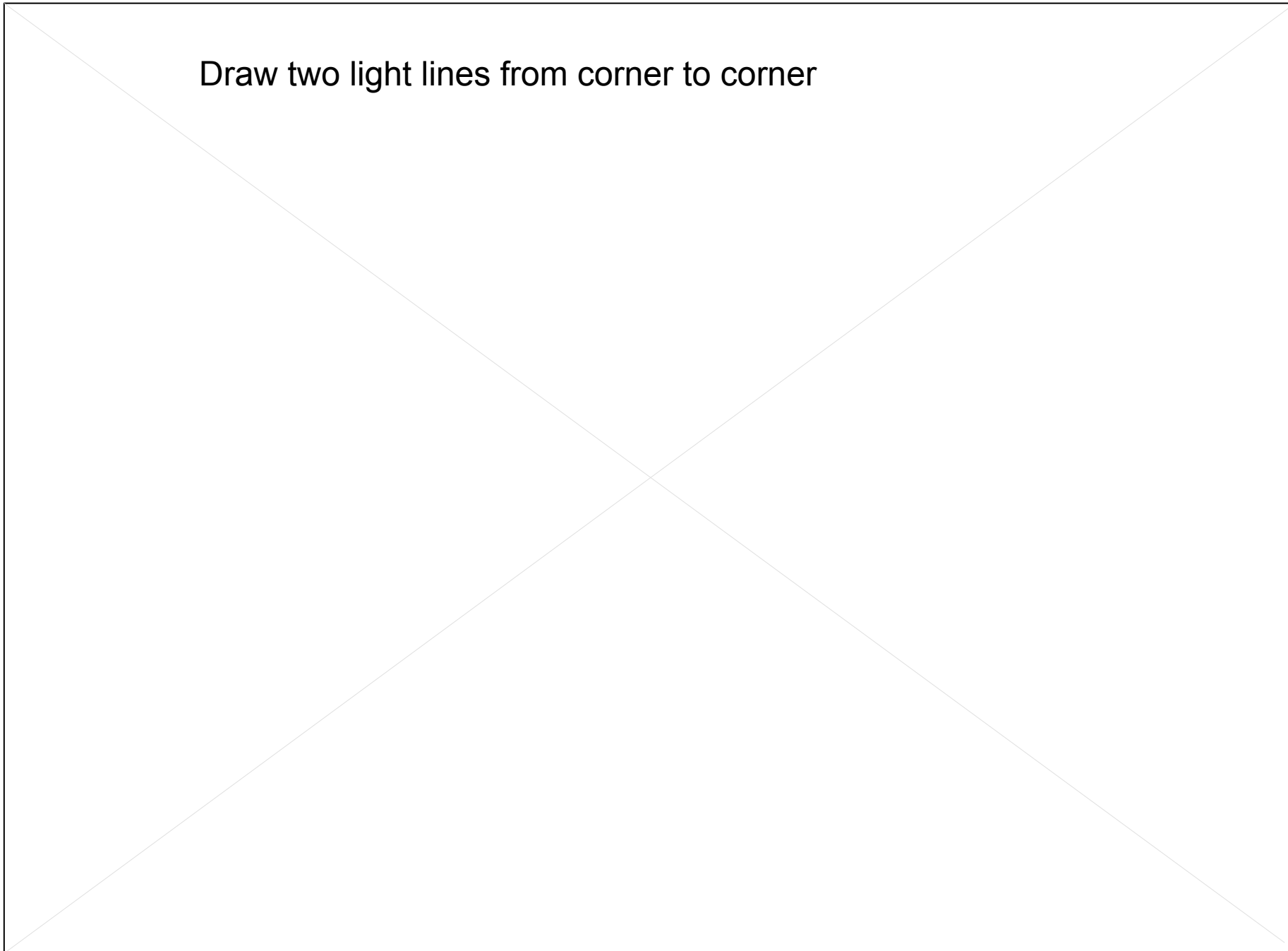

Draw a rectangle that touches the diagonal lines
you have just drawn.

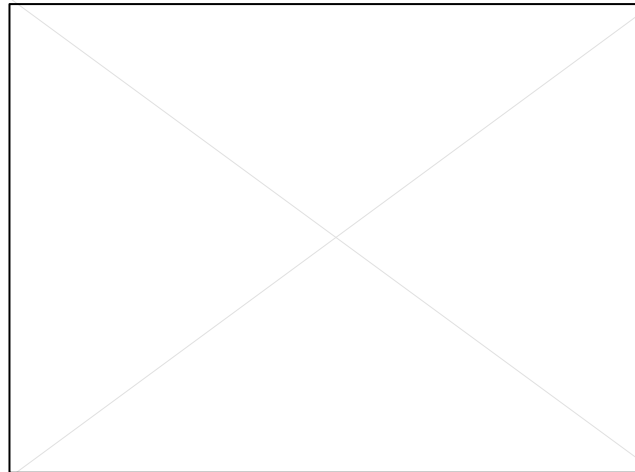

Draw a dot (vanishing point) where the lines cross.

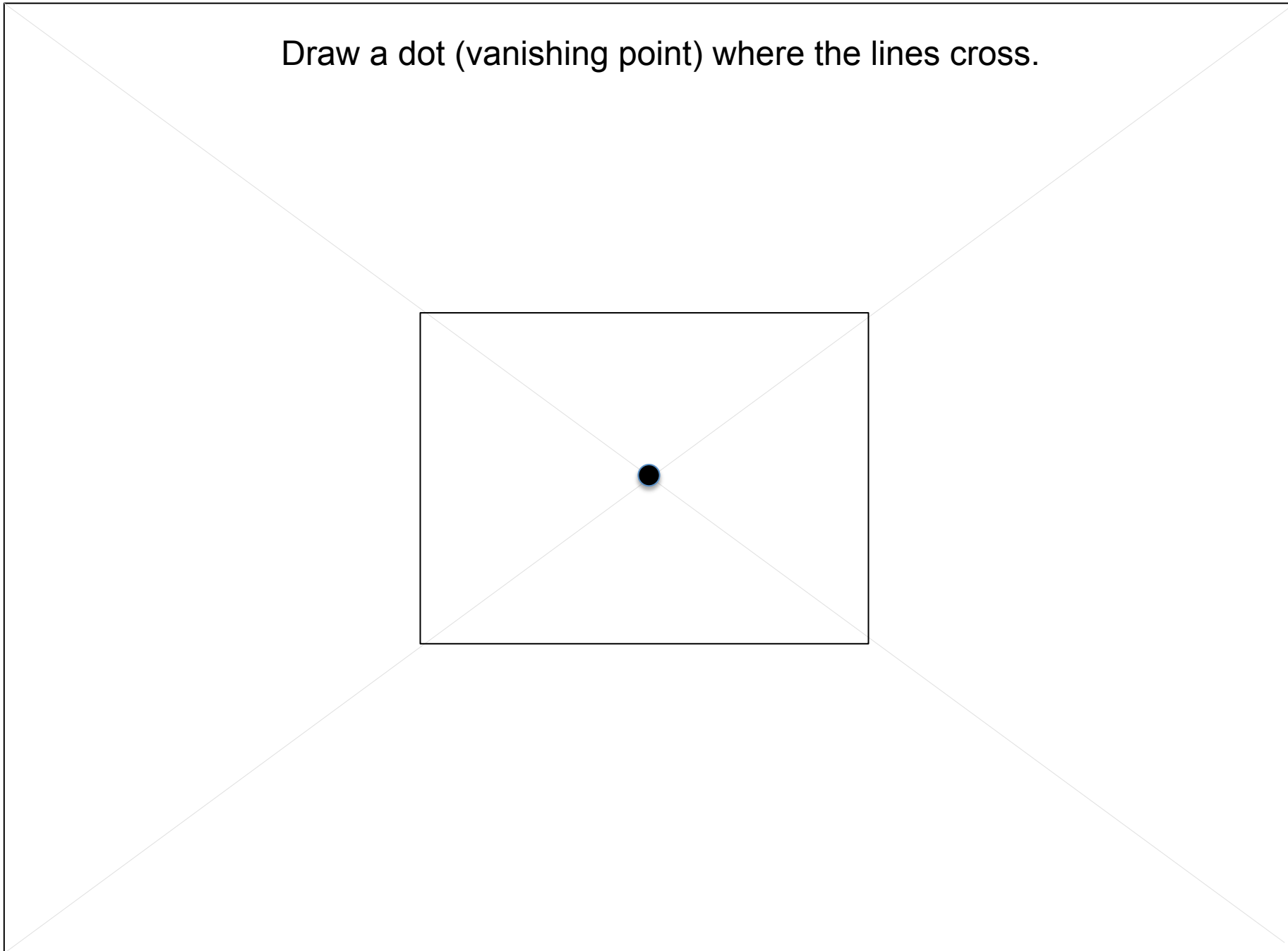

Delete the lines inside the smaller square. Keep the
vanishing point (dot).



Delete the lines inside the smaller square. Keep the vanishing point (dot).

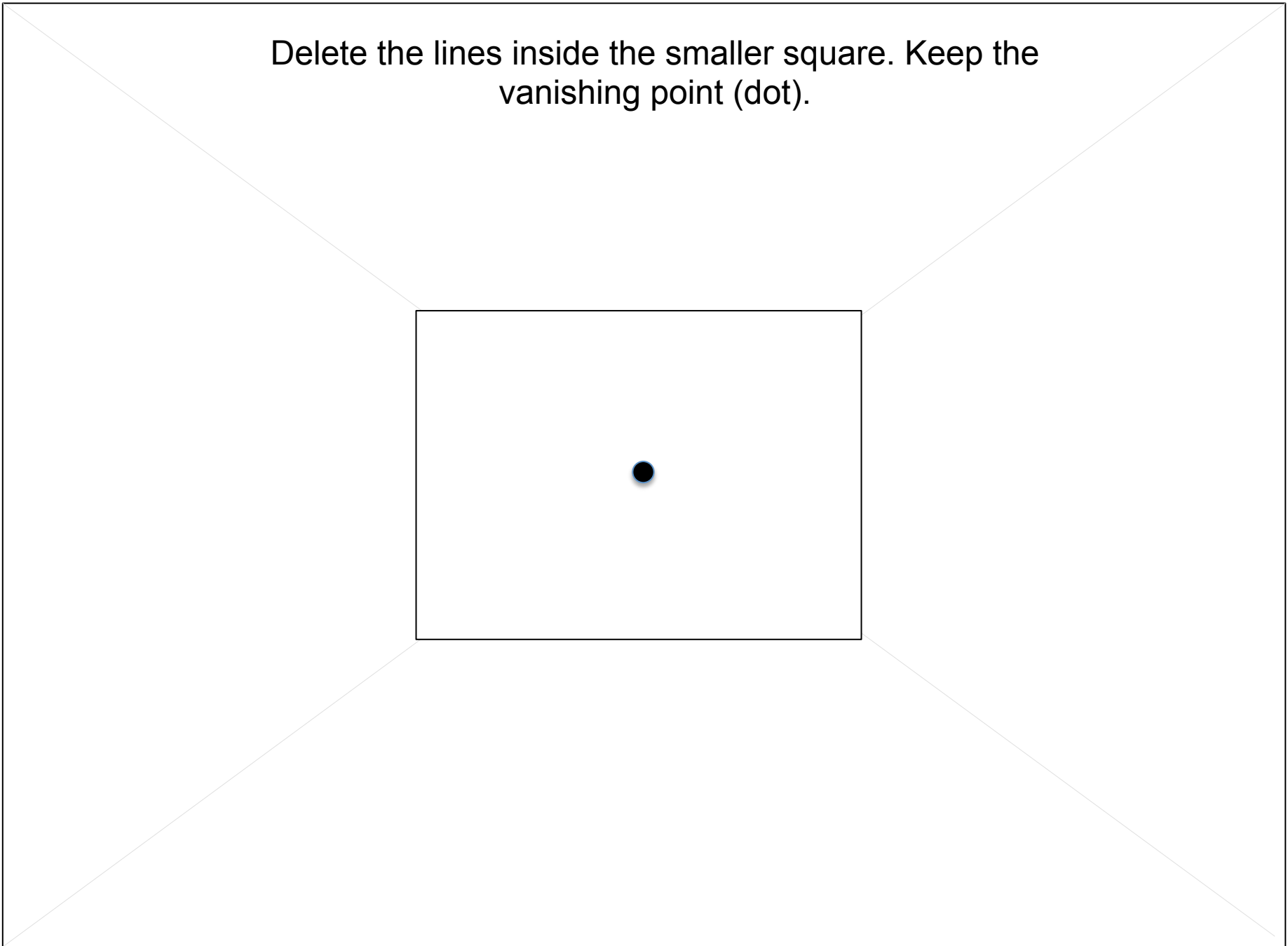

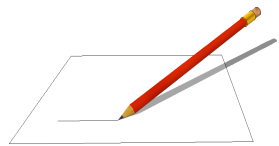

Hints: Sharp Pencil
Light Lines

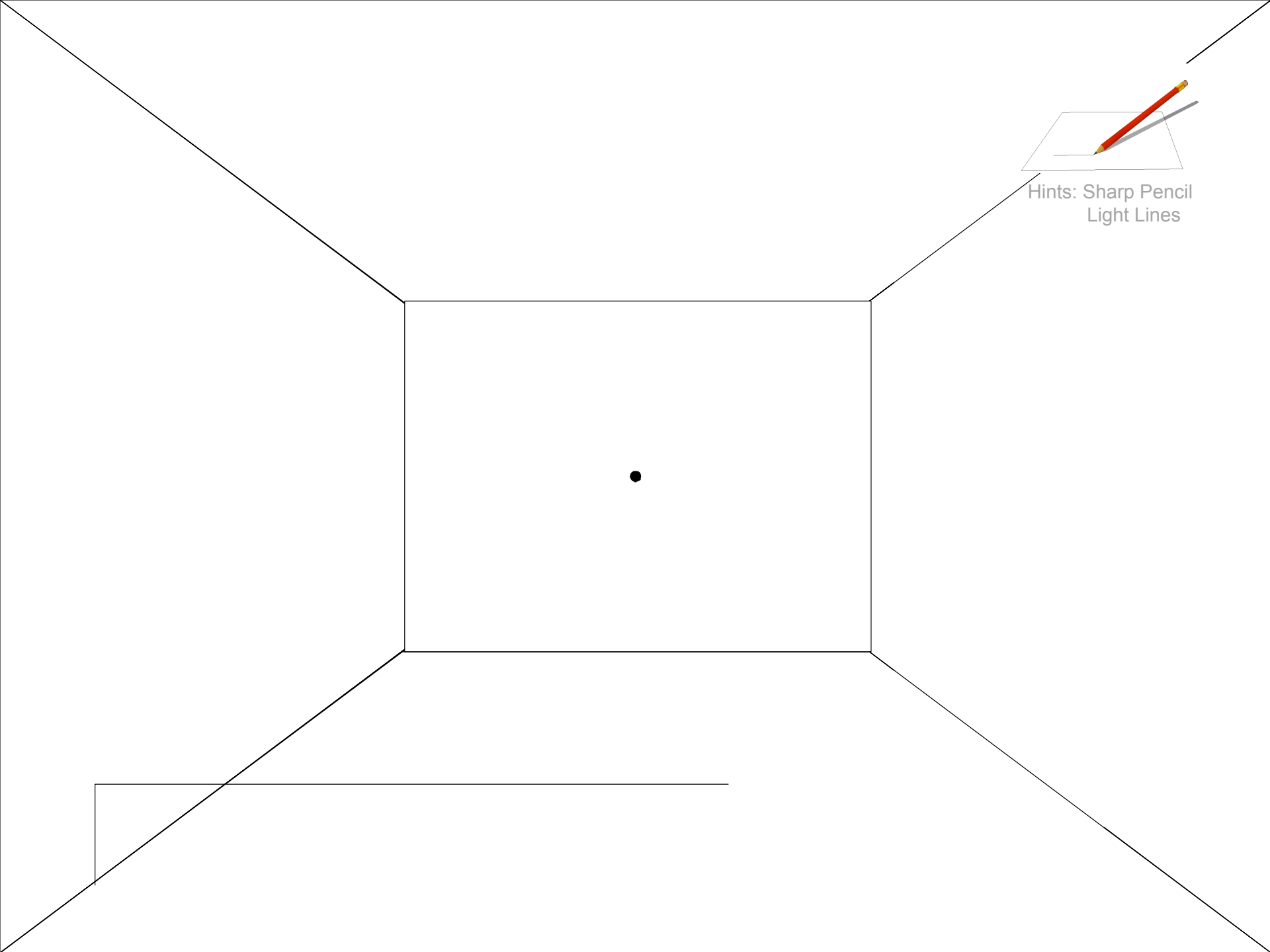

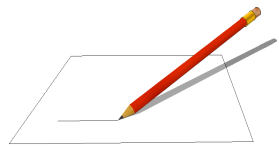

Hints: Sharp Pencil
Light Lines

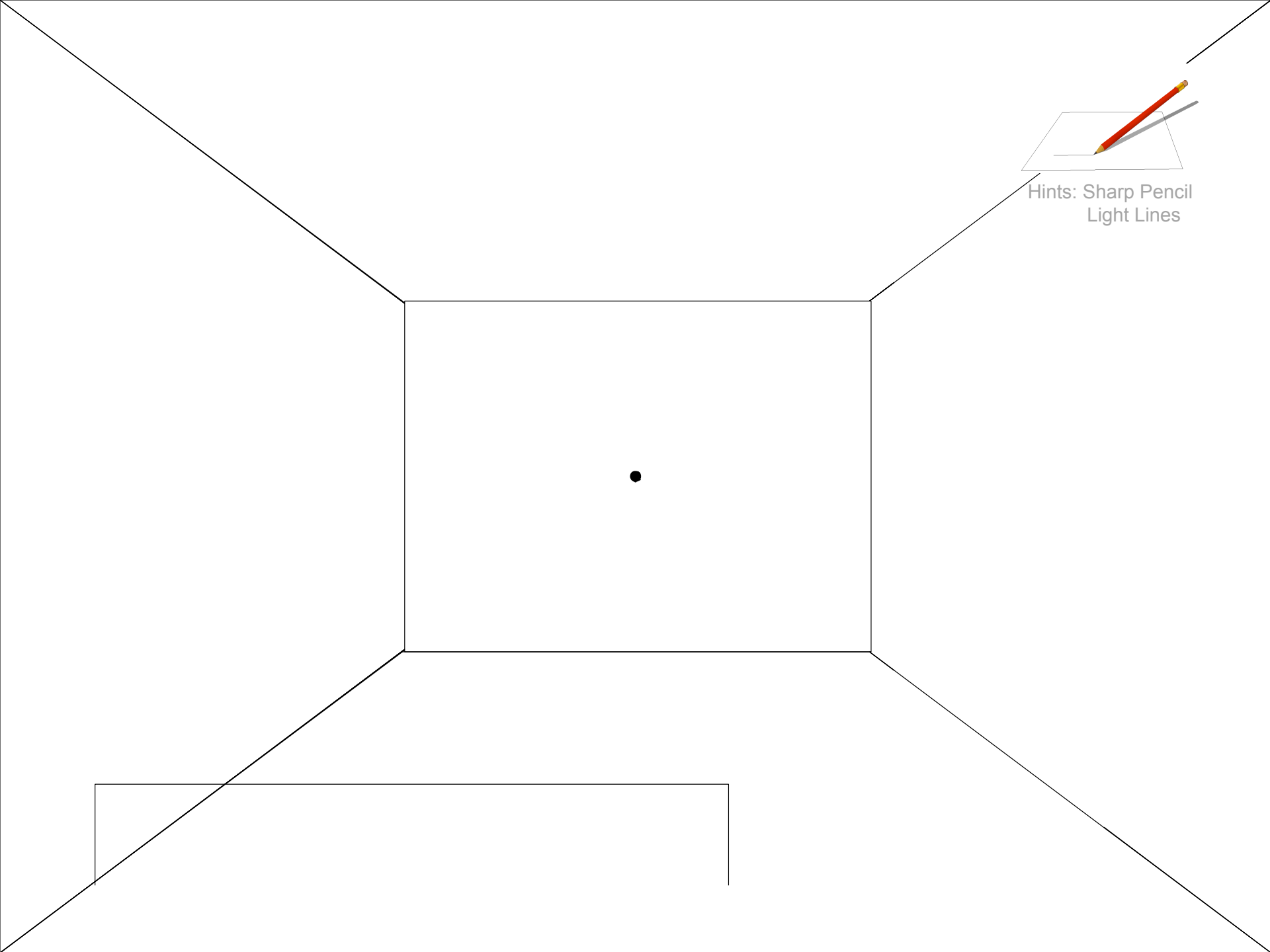

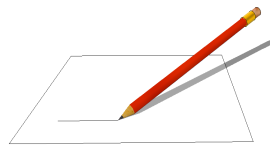

Hints: Sharp Pencil
Light Lines

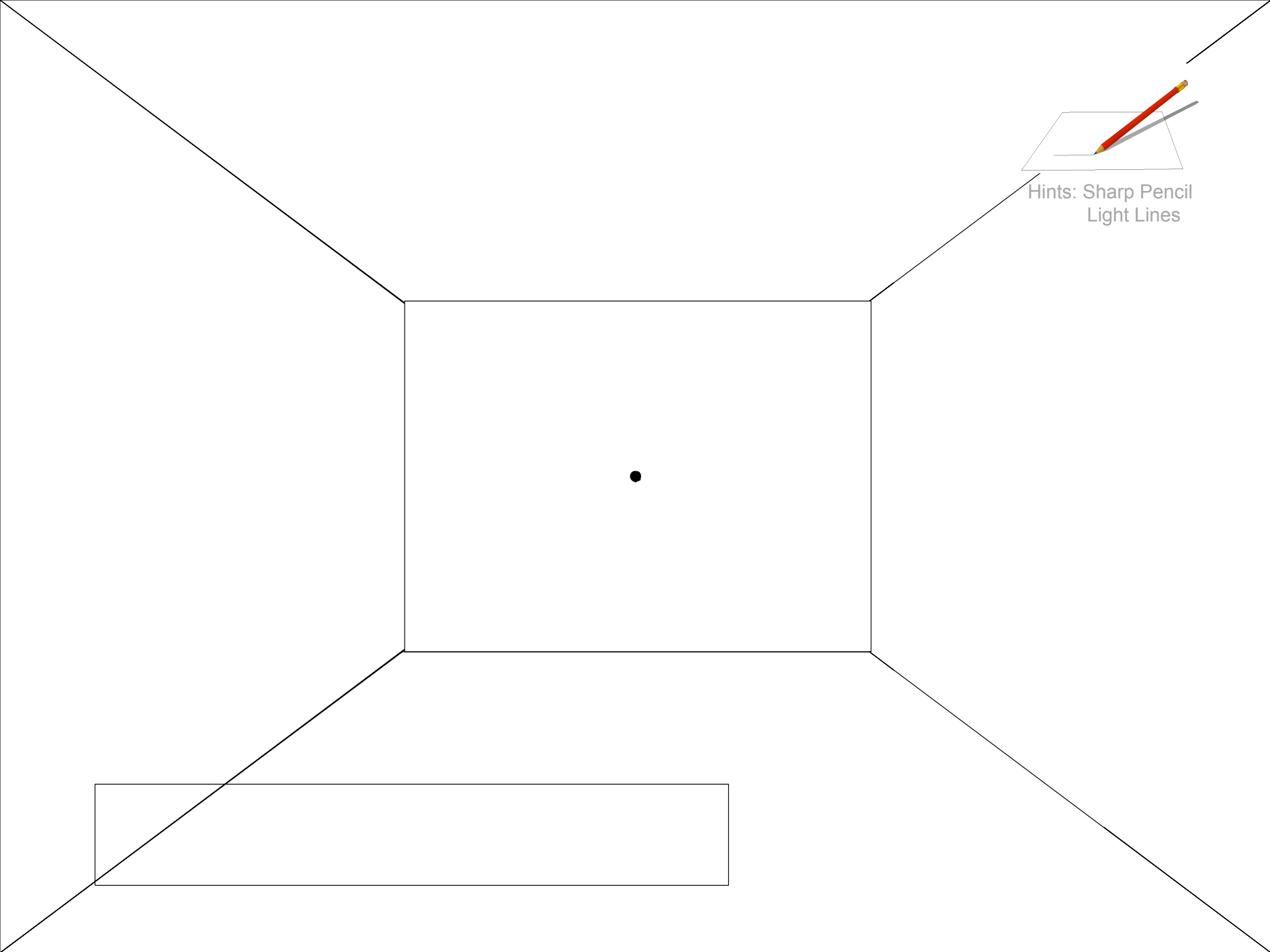

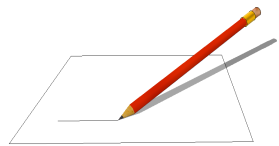

Hints: Sharp Pencil
Light Lines

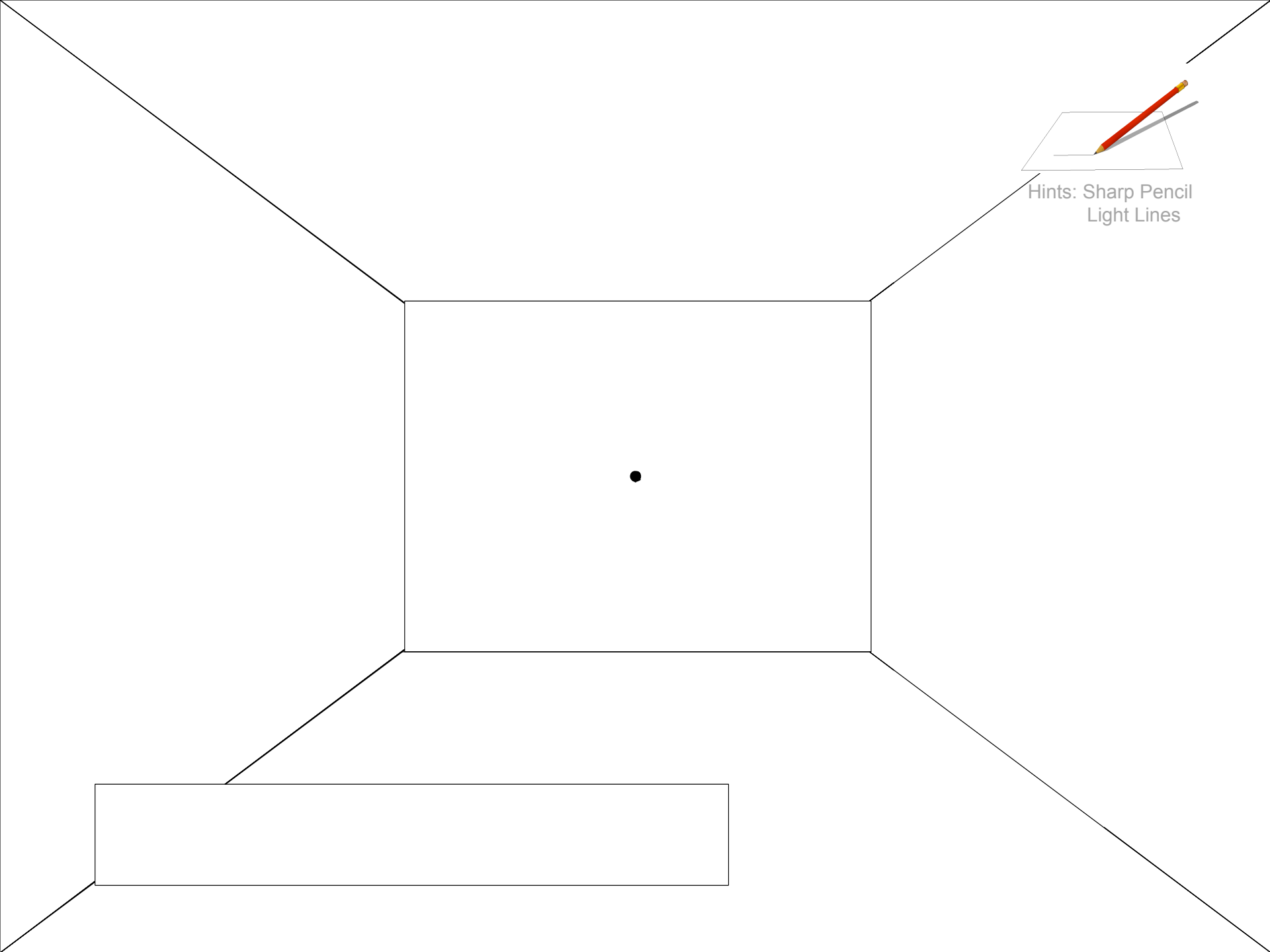

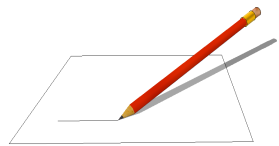

Hints: Sharp Pencil
Light Lines

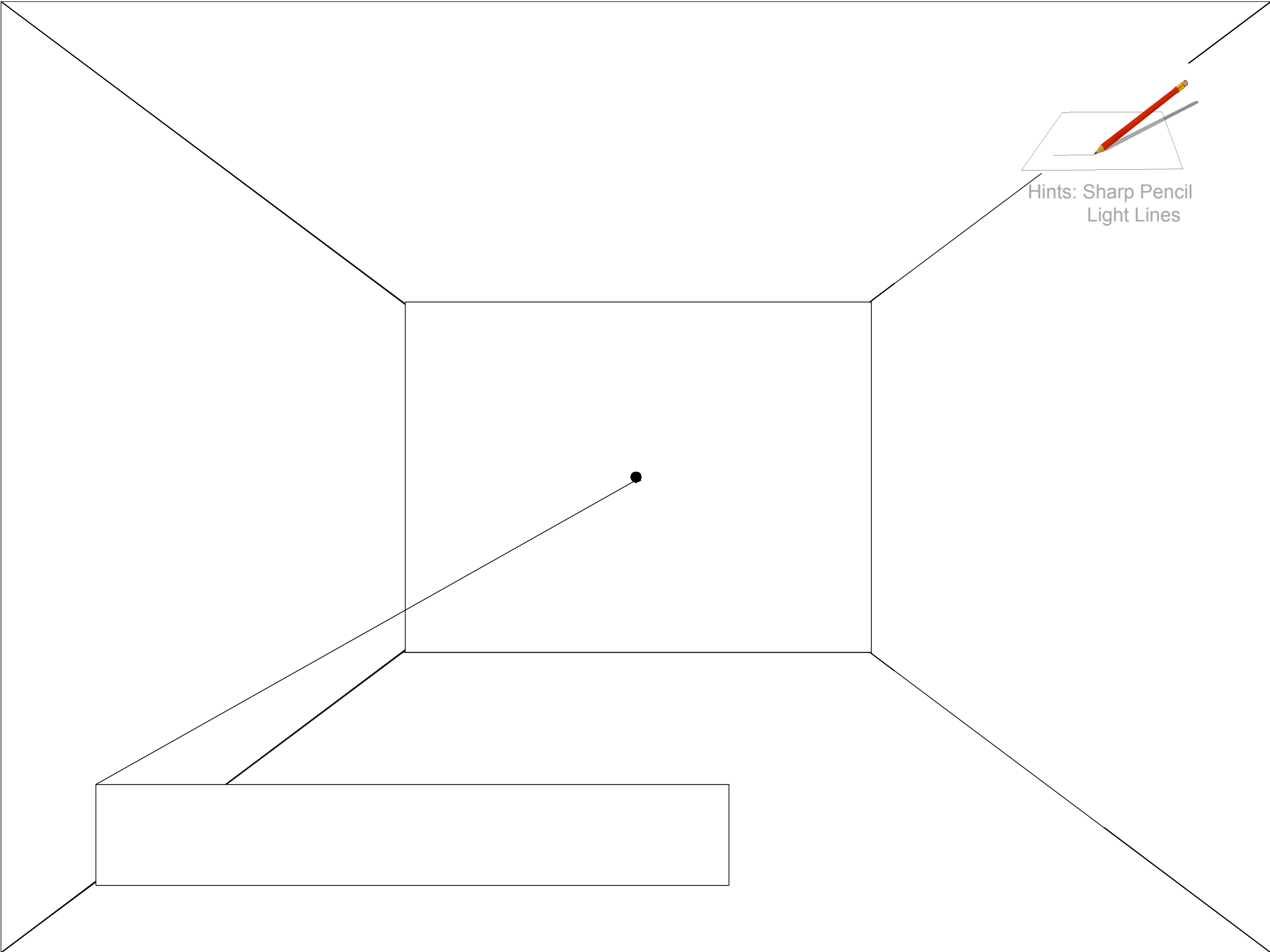

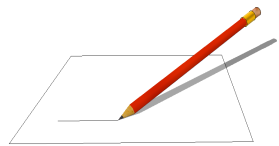

Hints: Sharp Pencil
Light Lines

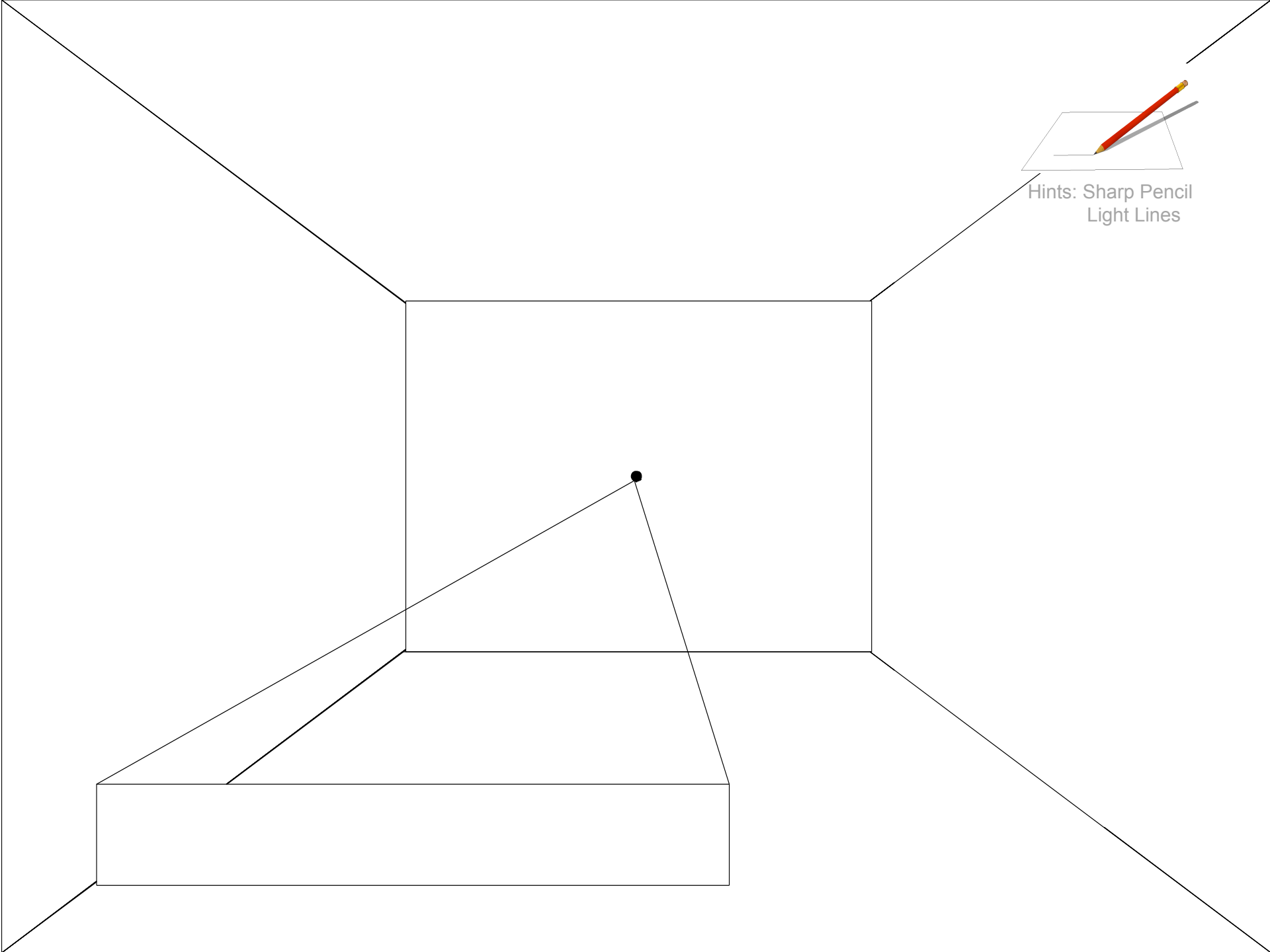

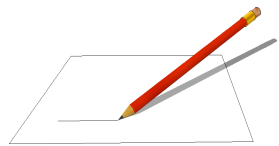

Hints: Sharp Pencil
Light Lines

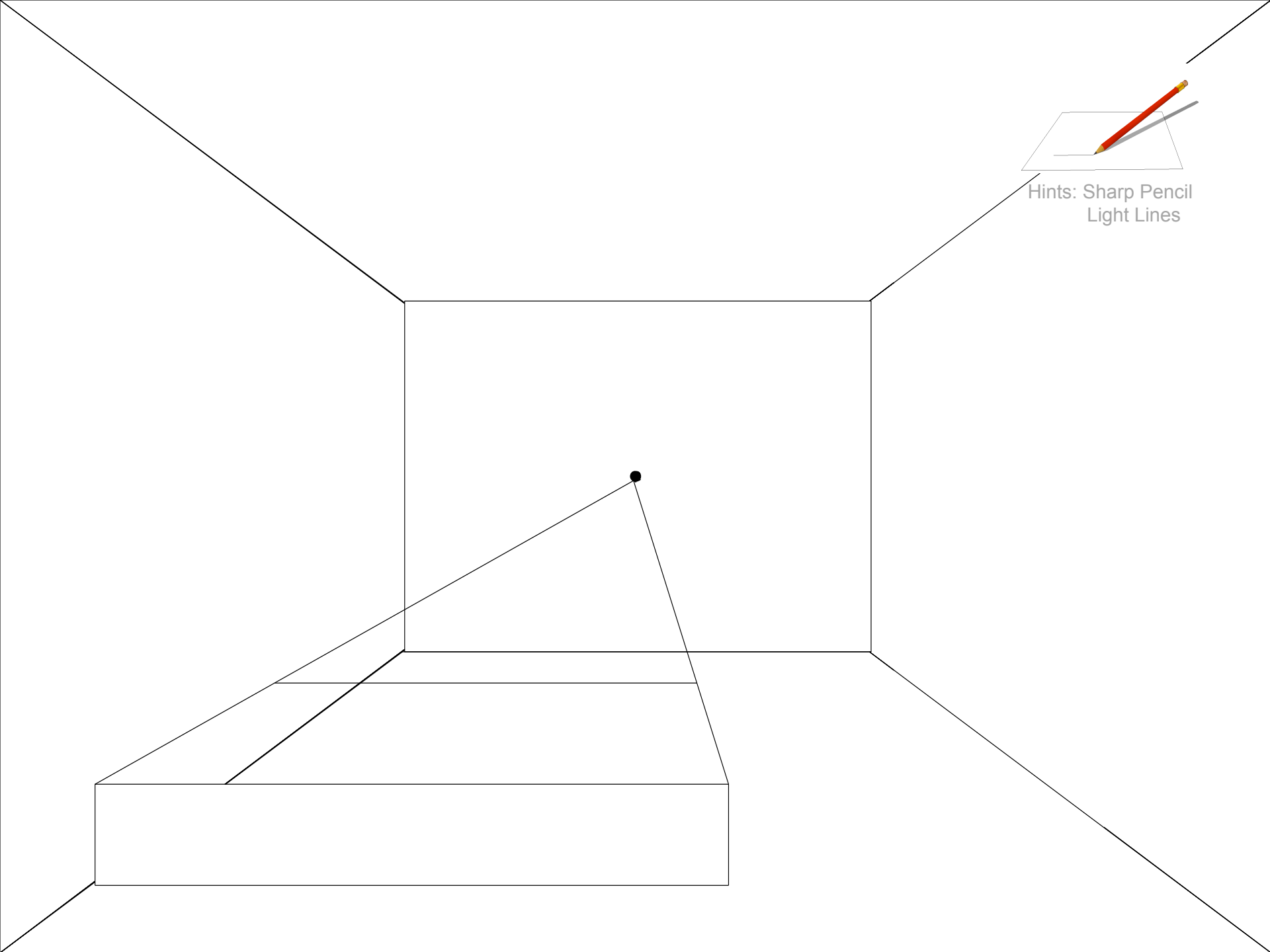

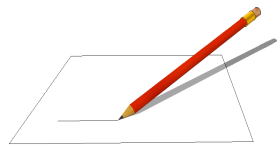

Hints: Sharp Pencil
Light Lines

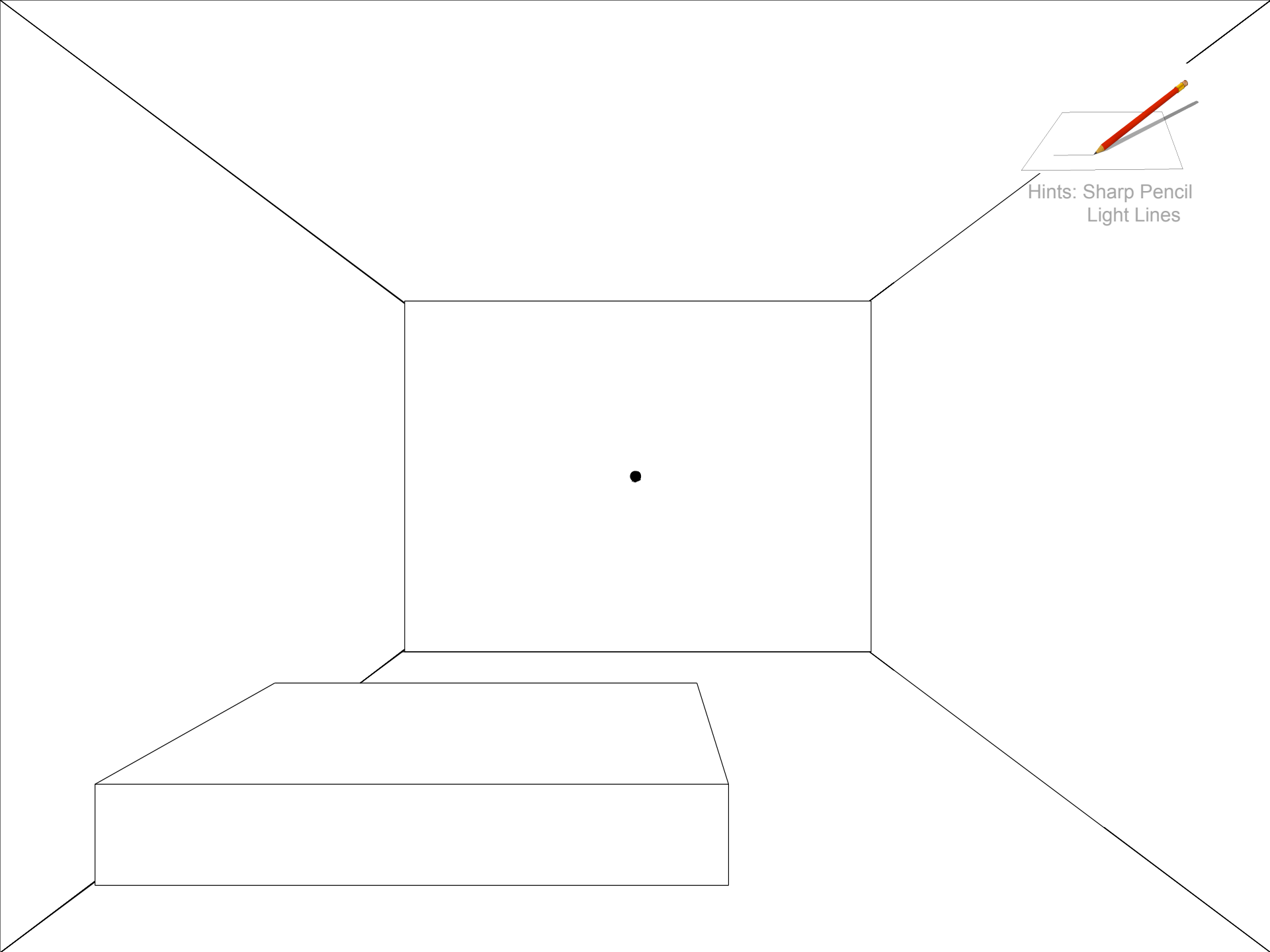

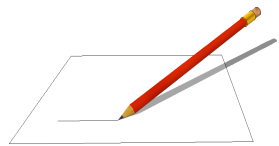

Hints: Sharp Pencil
Light Lines

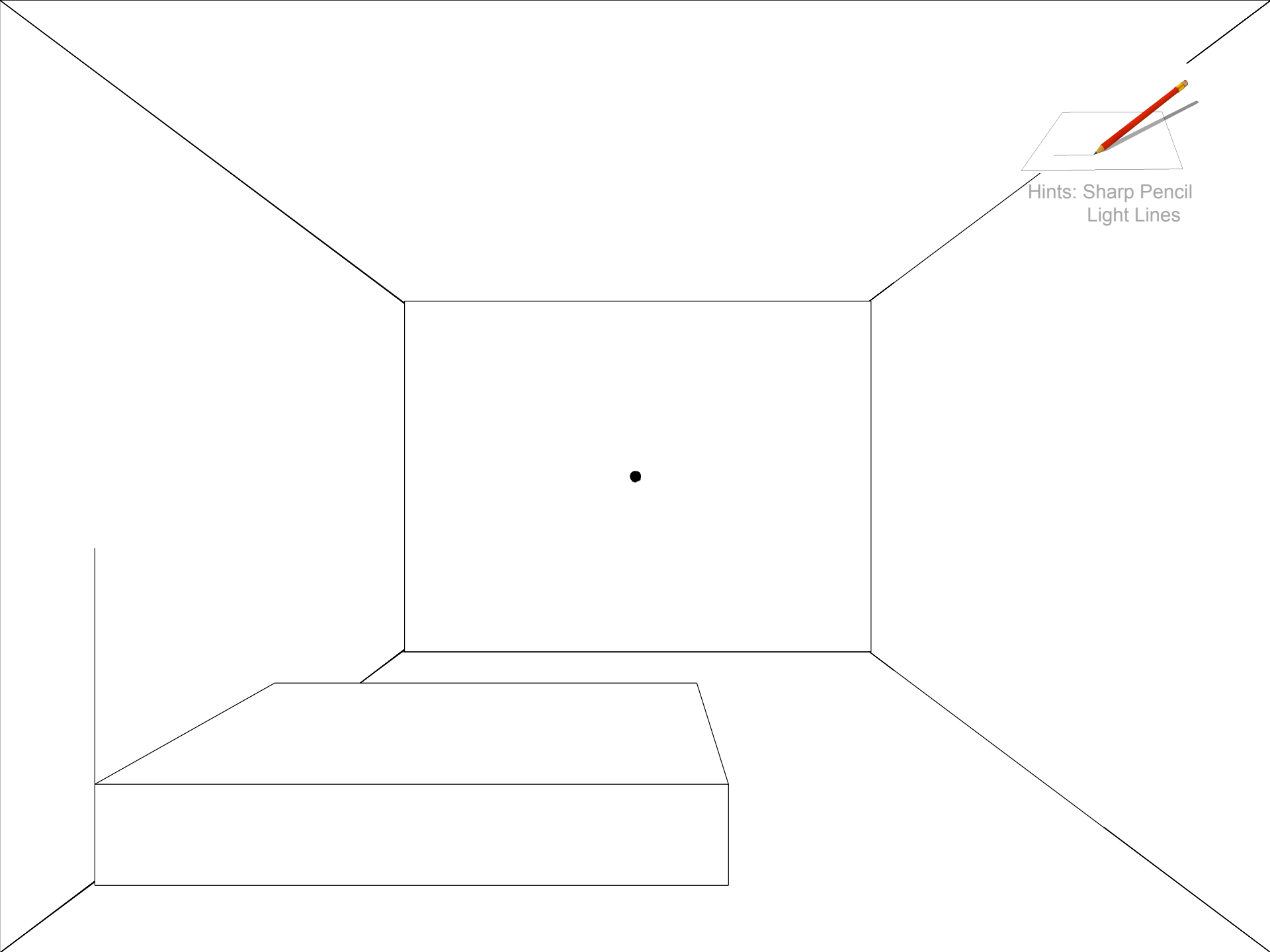

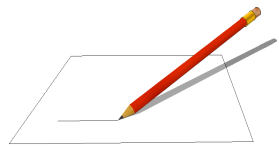

Hints: Sharp Pencil
Light Lines

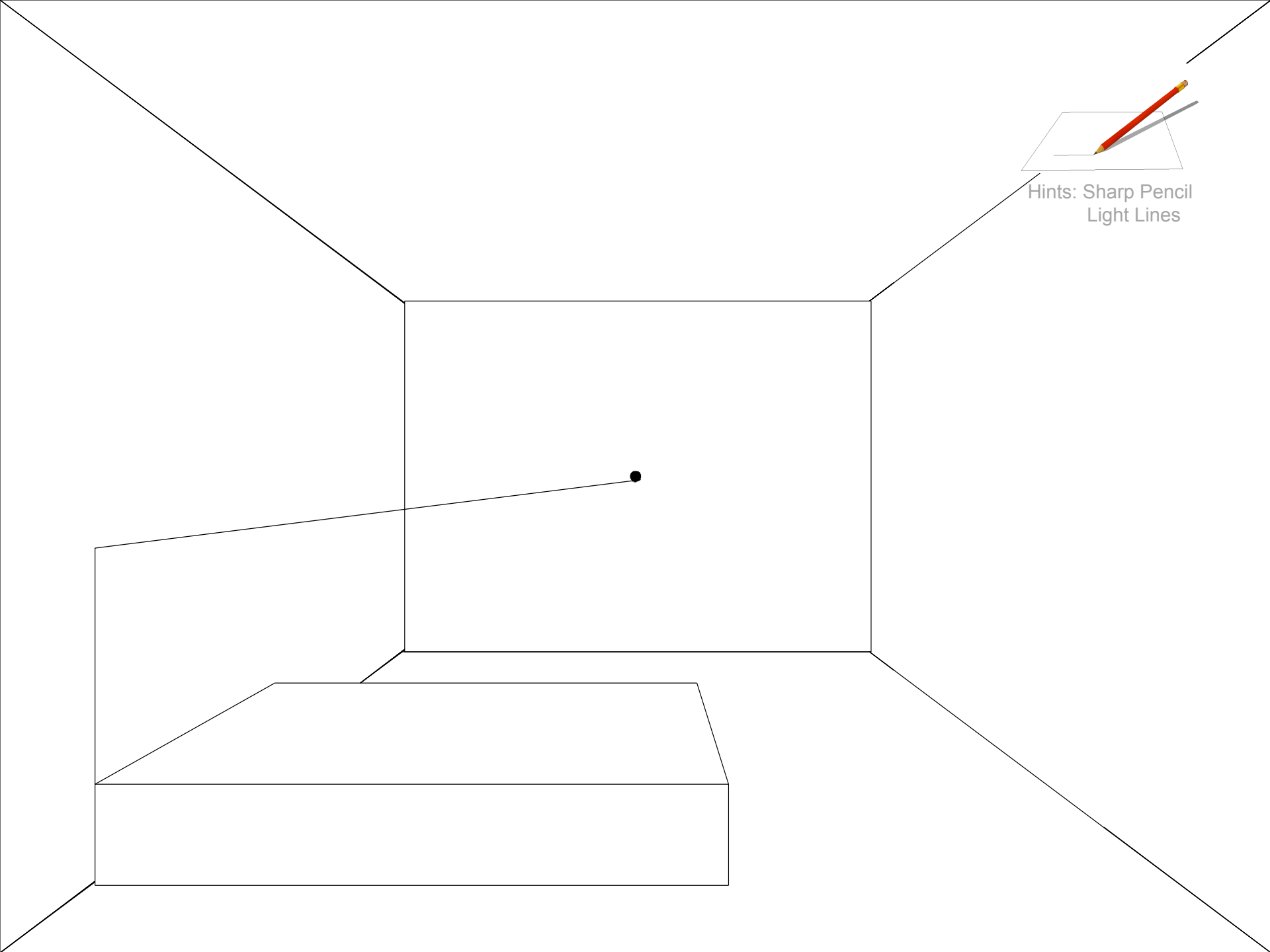

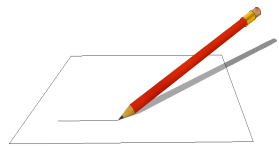

Hints: Sharp Pencil
Light Lines

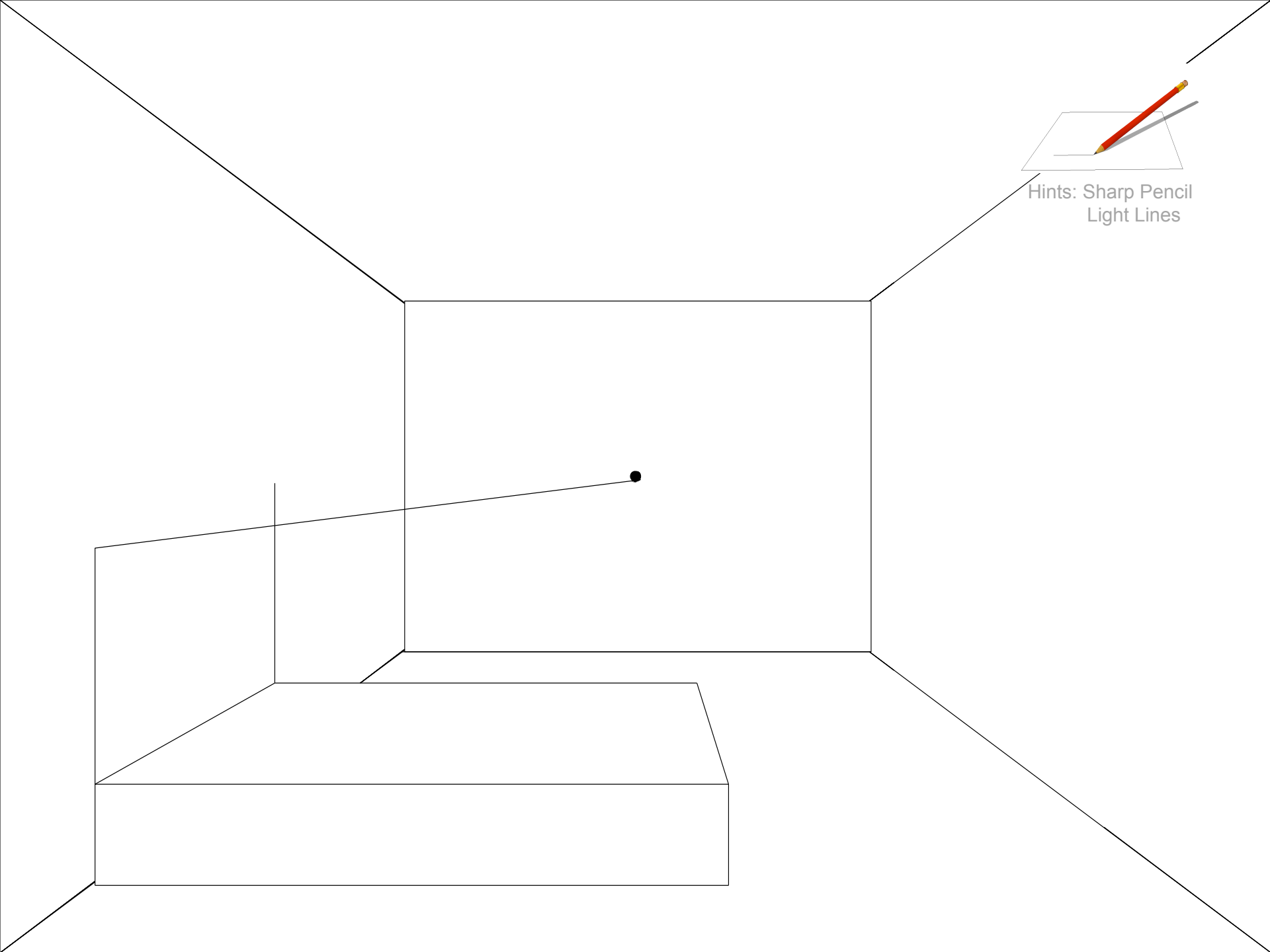

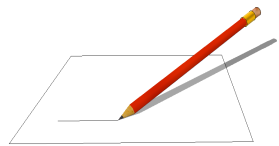

Hints: Sharp Pencil
Light Lines

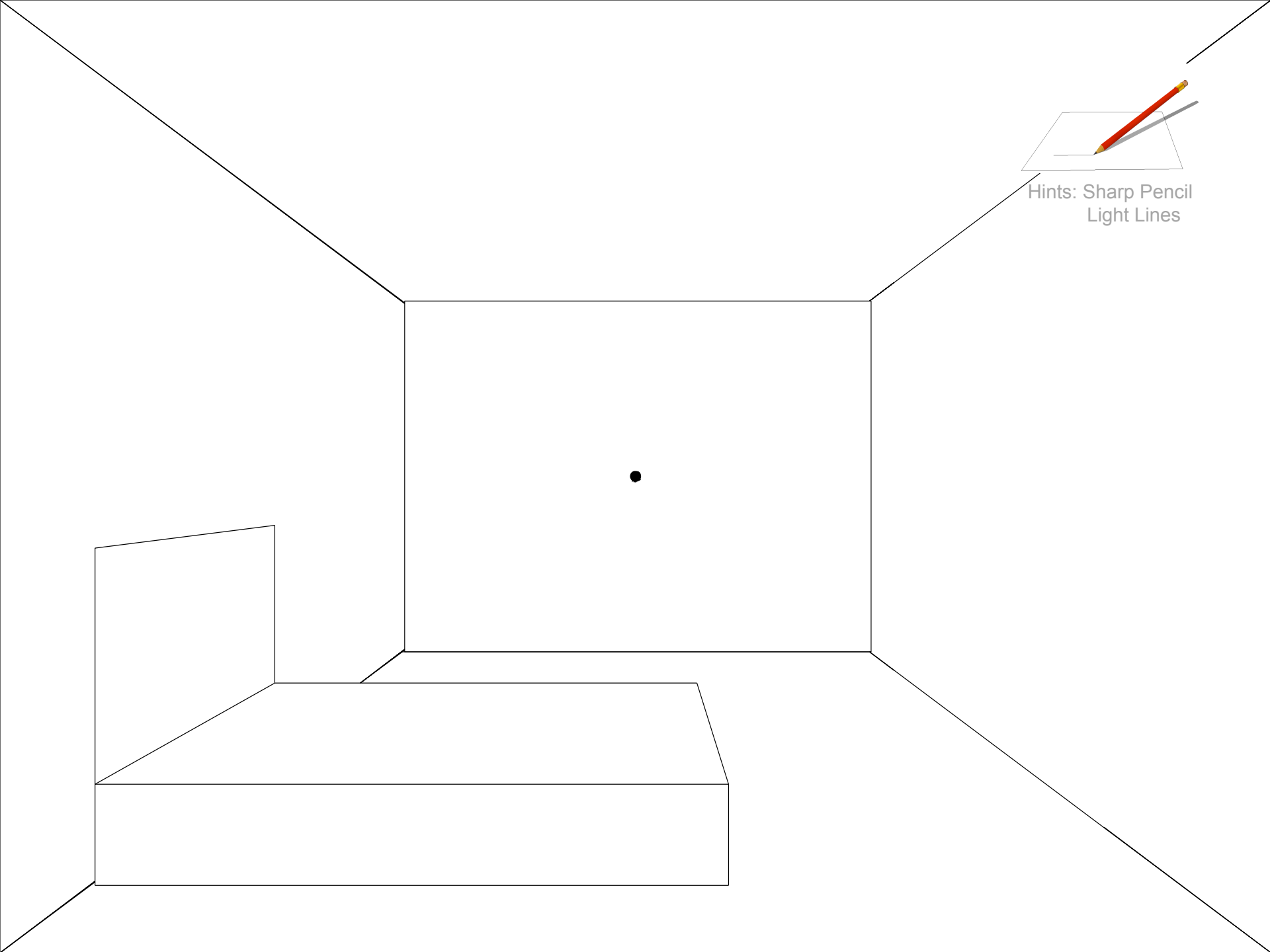

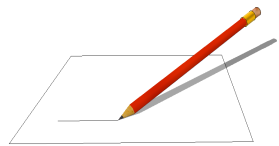

Hints: Sharp Pencil
Light Lines

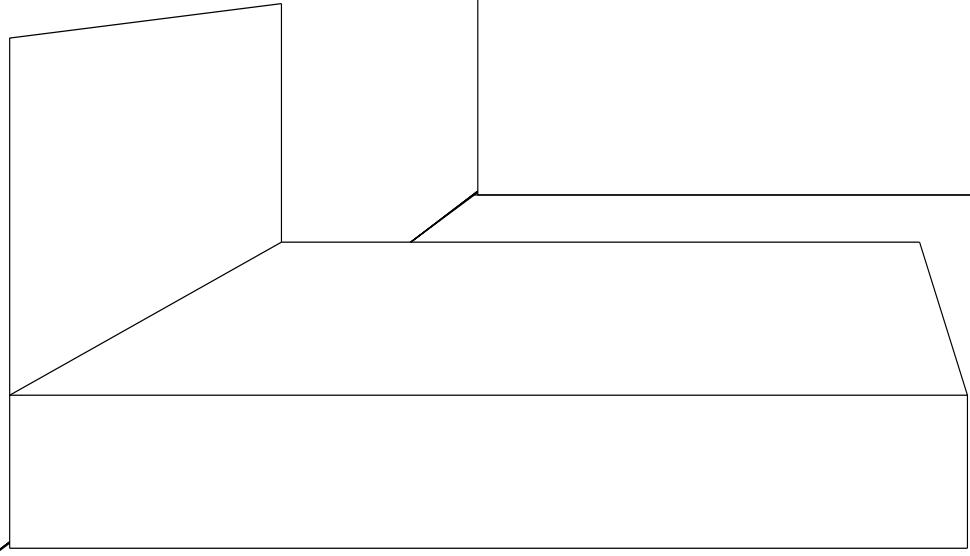

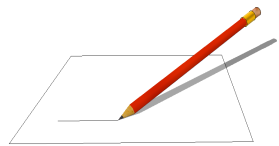

Hints: Sharp Pencil
Light Lines

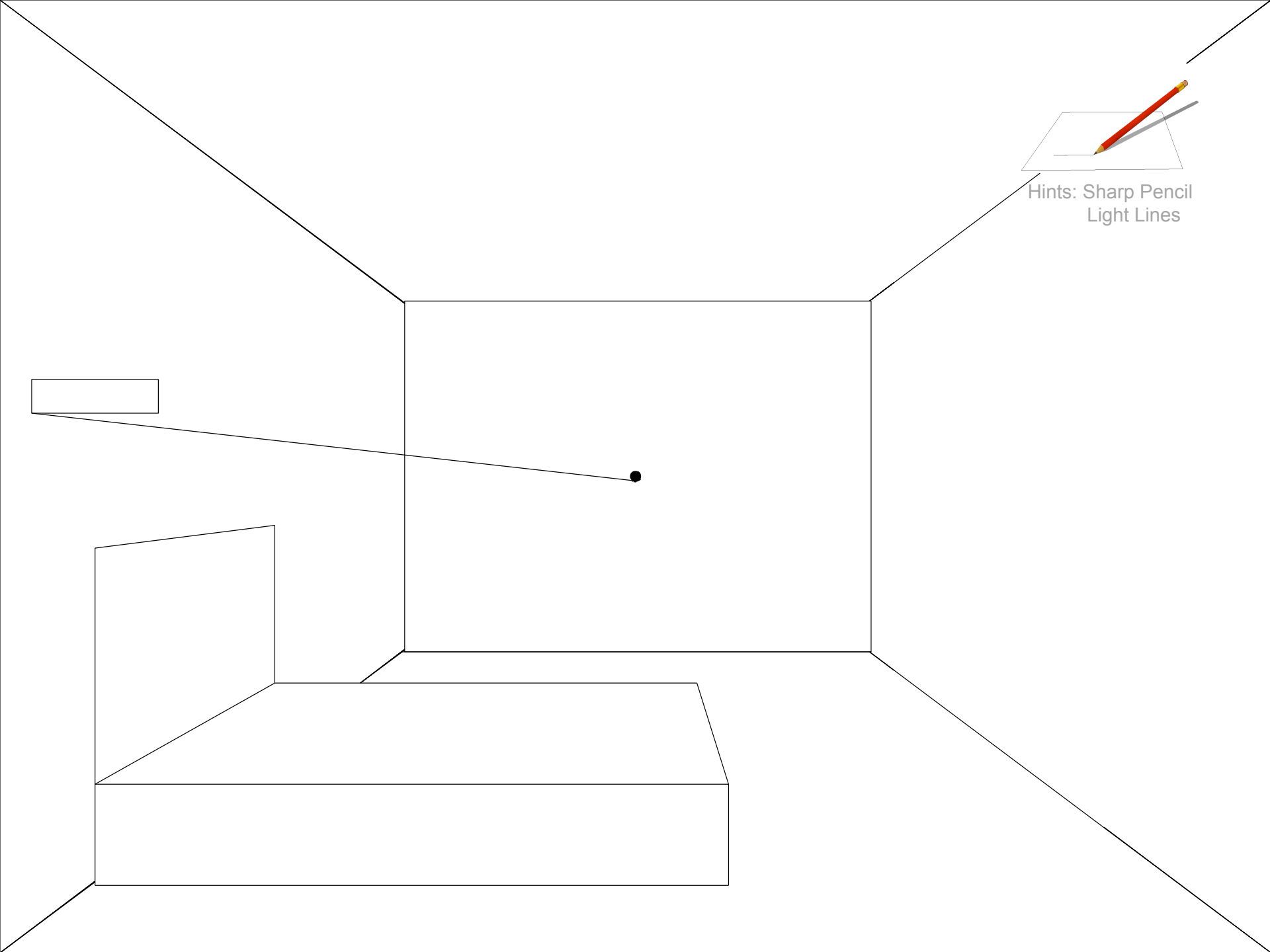

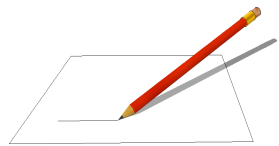

Hints: Sharp Pencil
Light Lines

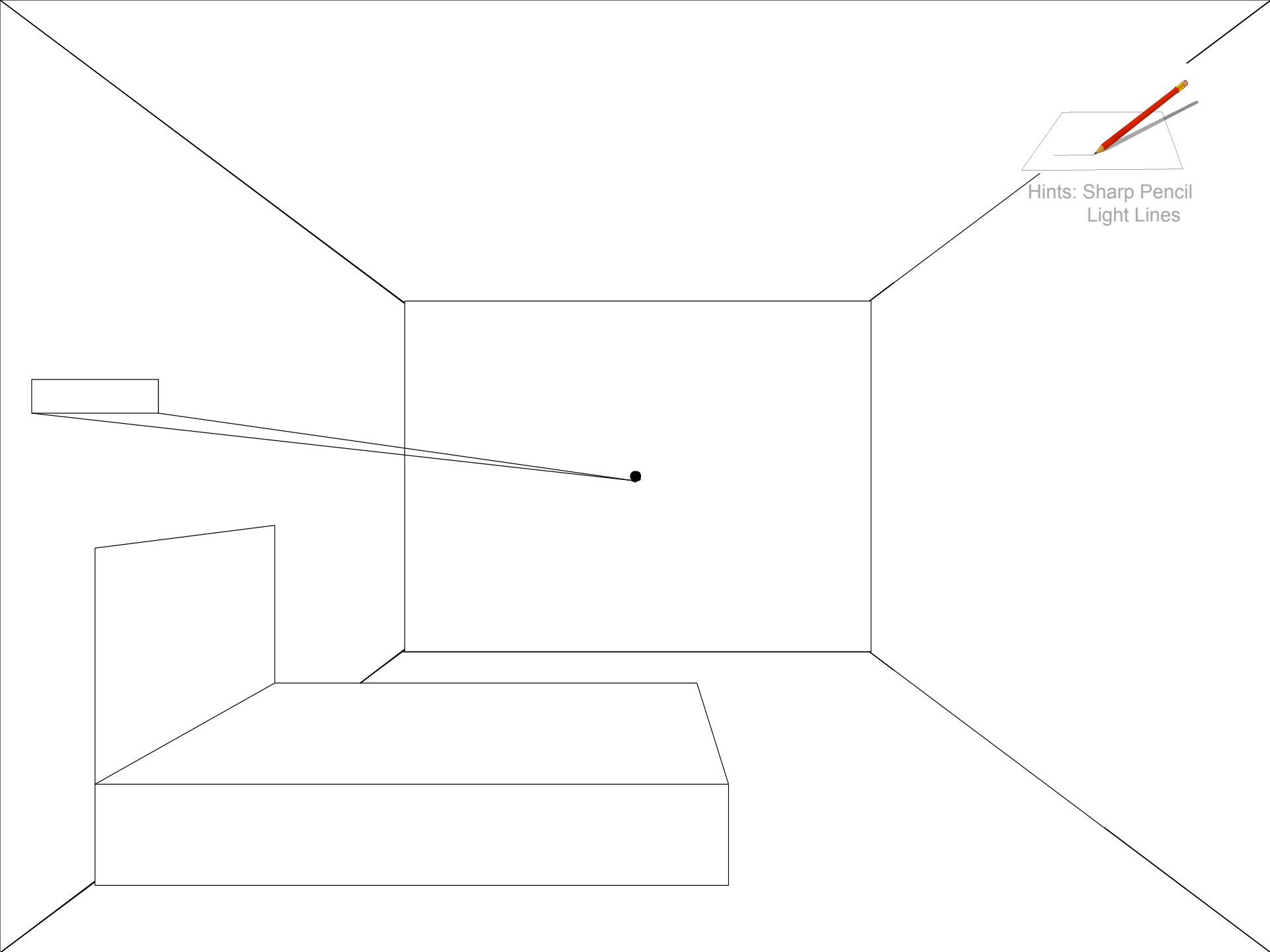

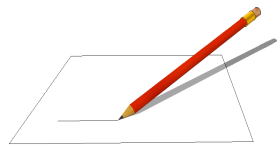

Hints: Sharp Pencil
Light Lines

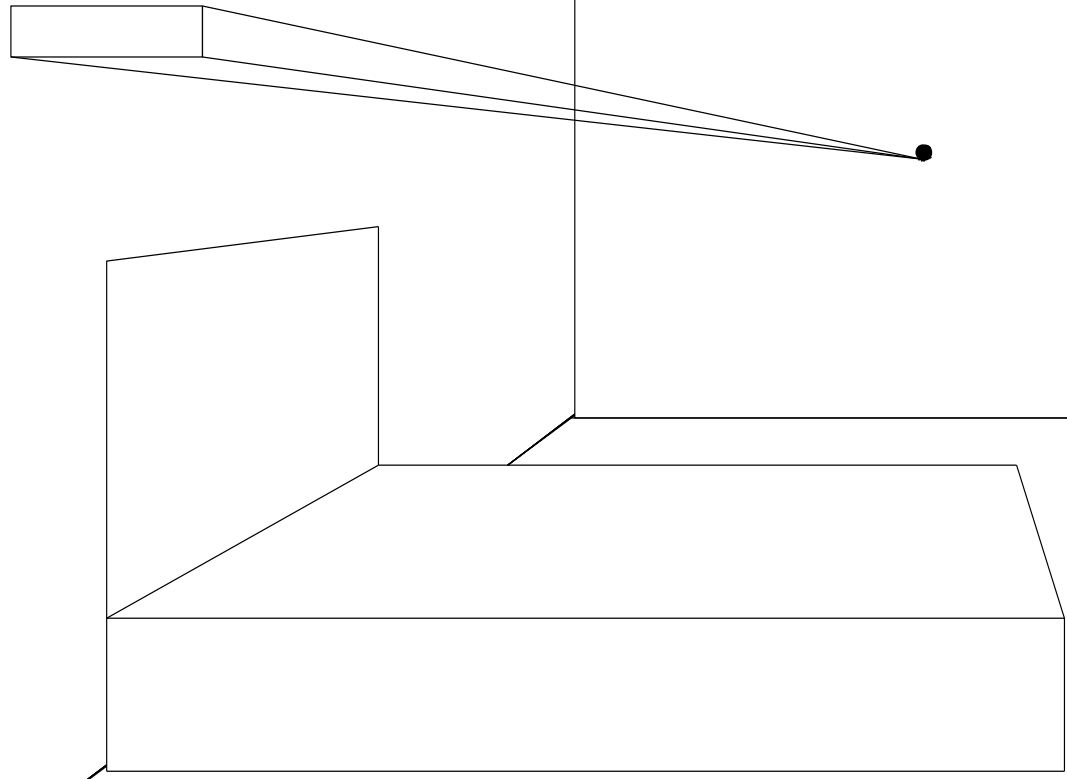

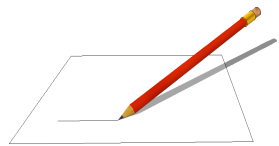

Hints: Sharp Pencil
Light Lines

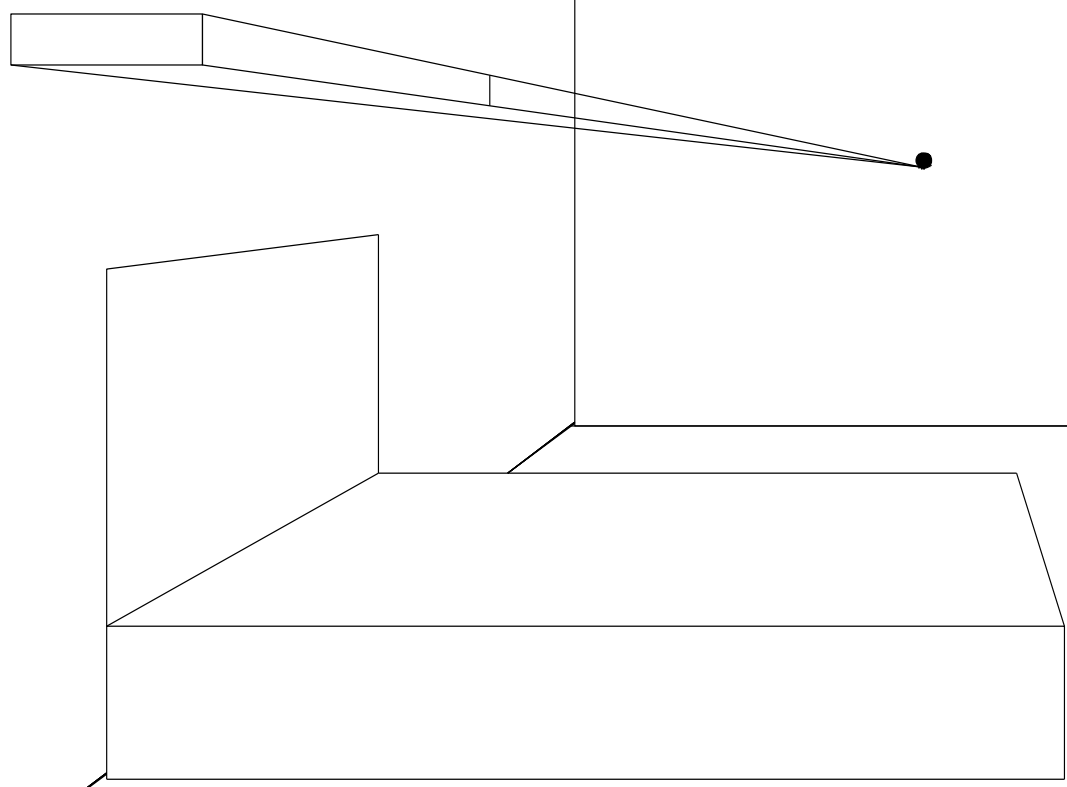

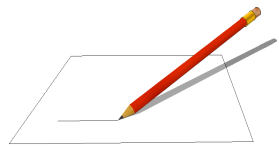

Hints: Sharp Pencil
Light Lines

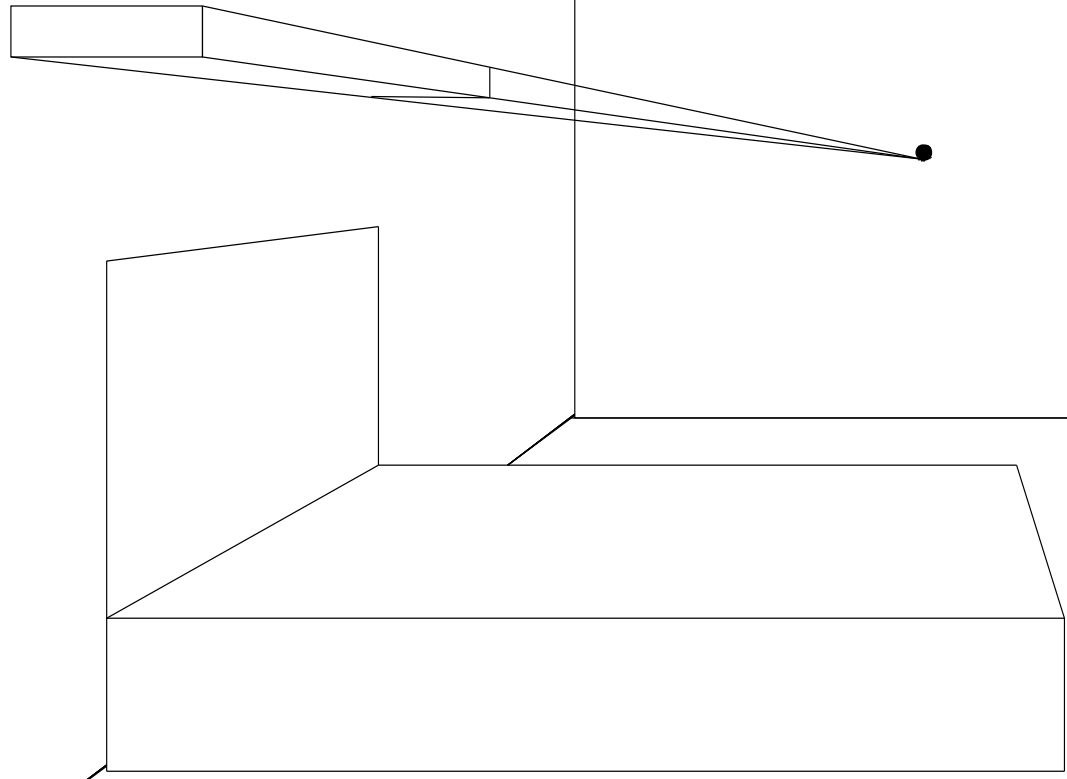

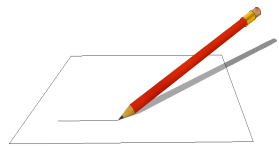

Hints: Sharp Pencil
Light Lines

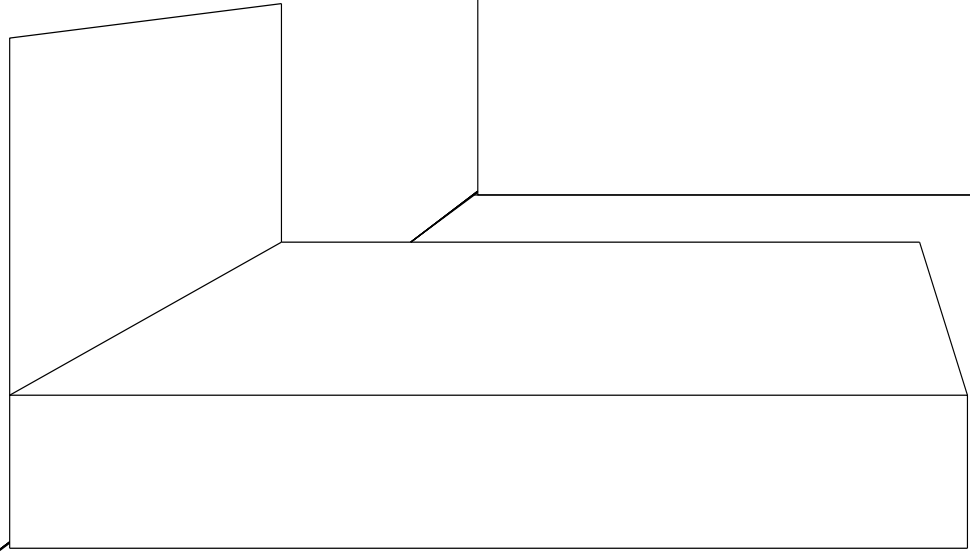
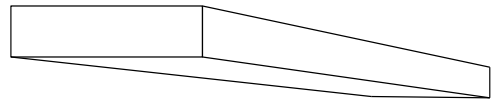

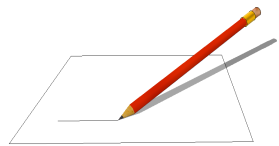

Hints: Sharp Pencil
Light Lines

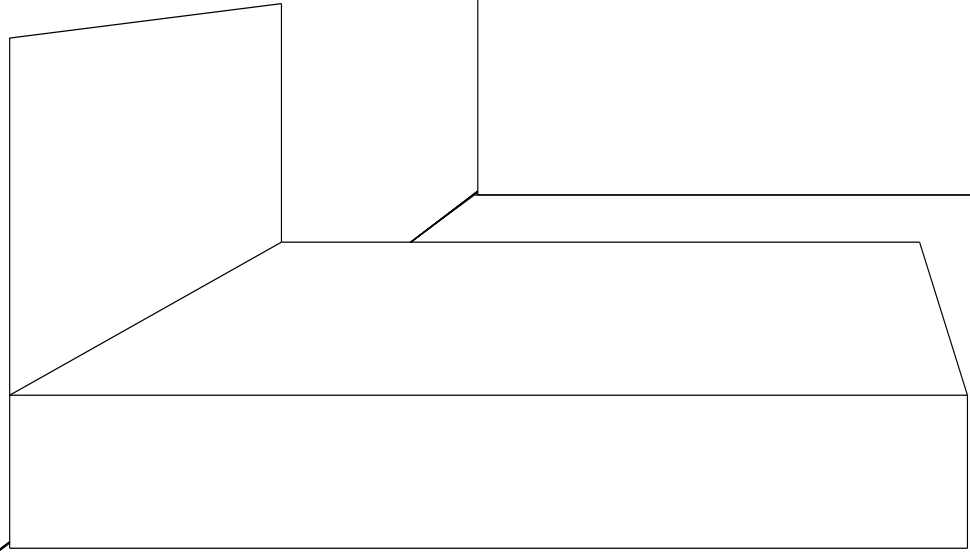
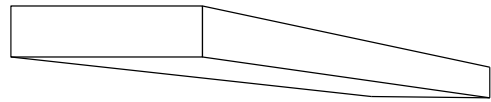

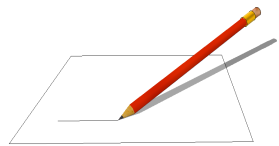

Hints: Sharp Pencil
Light Lines

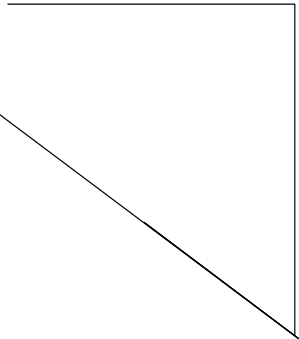
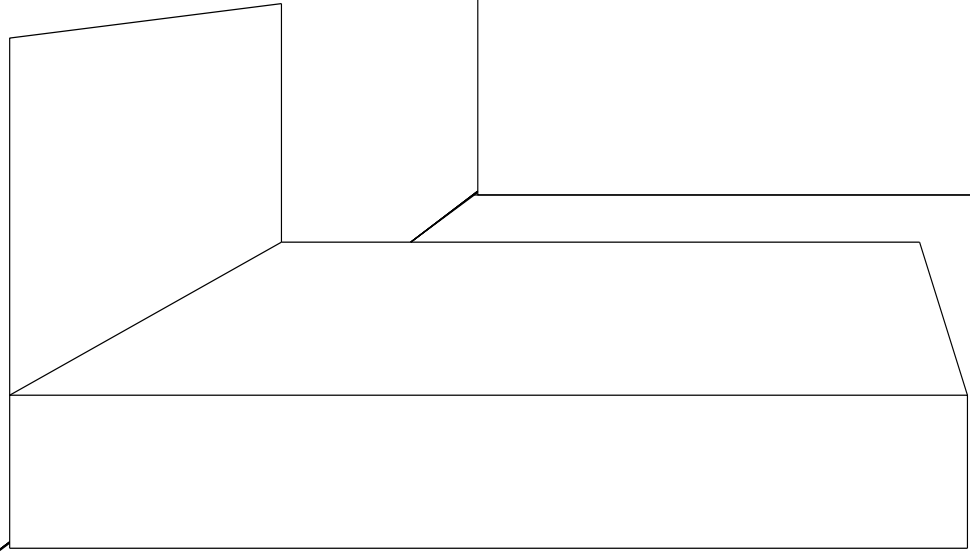
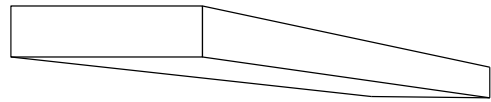

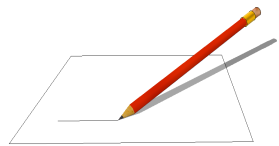

Hints: Sharp Pencil
Light Lines

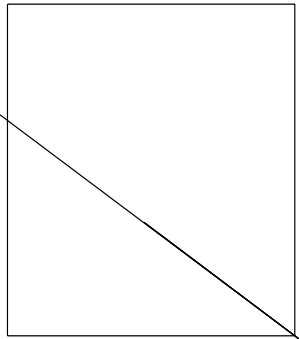
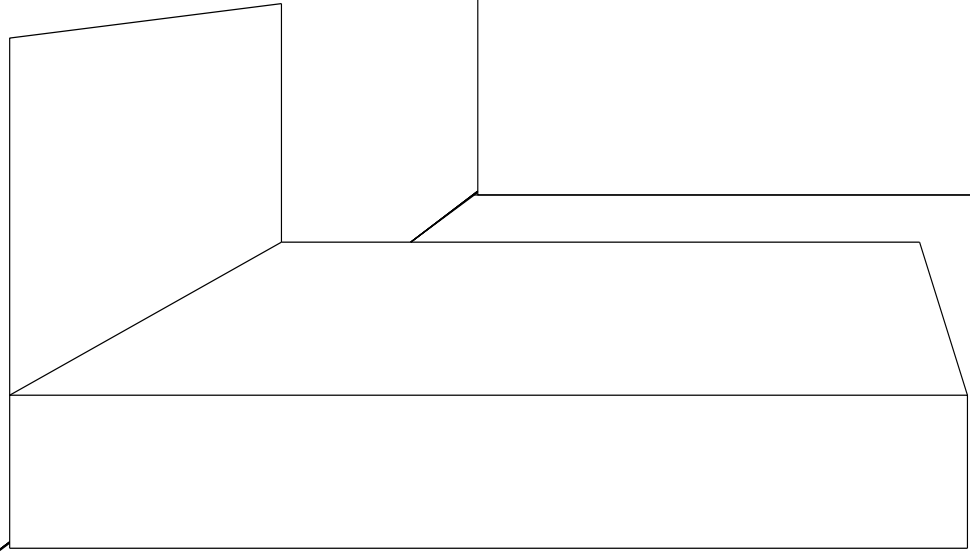
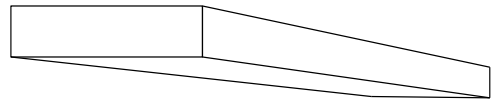

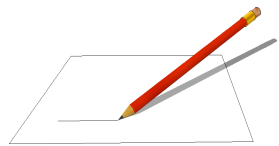

Hints: Sharp Pencil
Light Lines

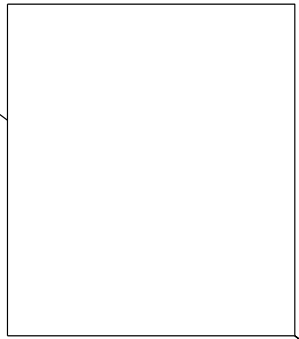
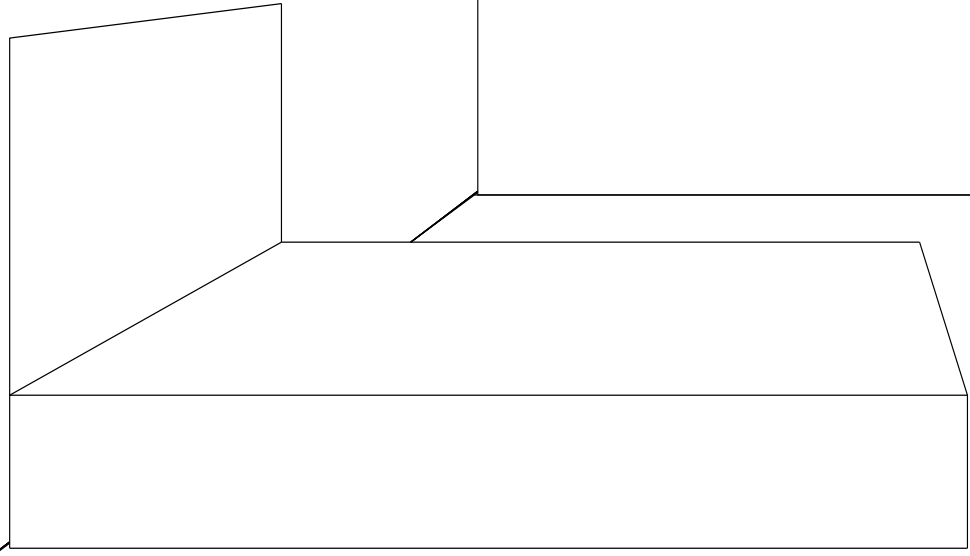
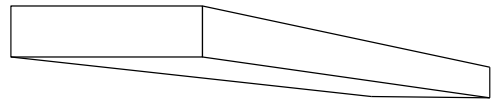

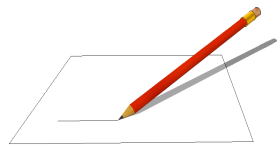

Hints: Sharp Pencil
Light Lines

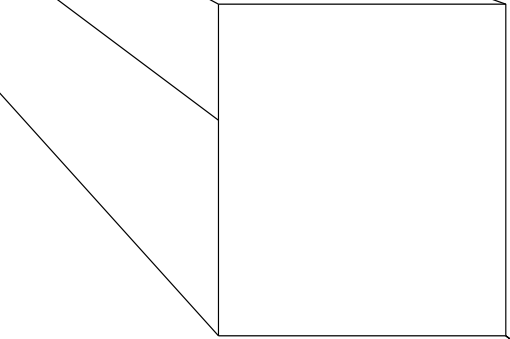
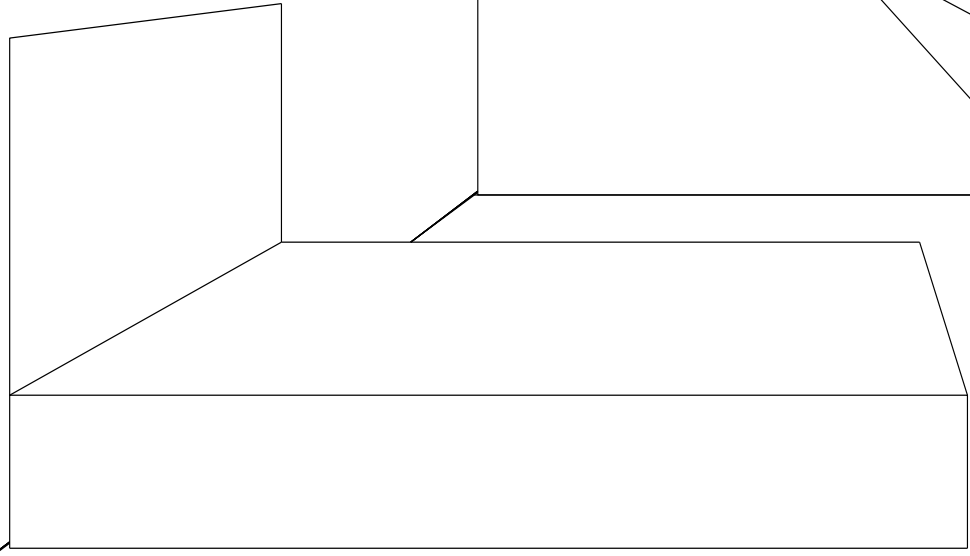
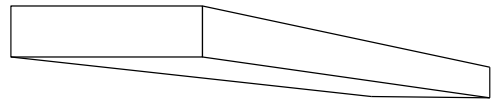

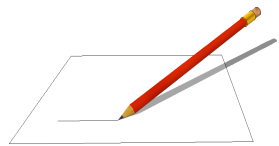

Hints: Sharp Pencil
Light Lines

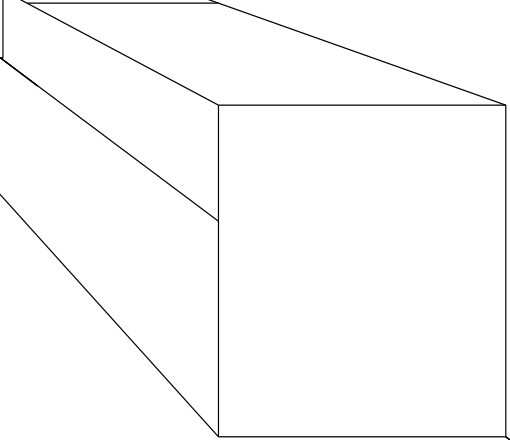
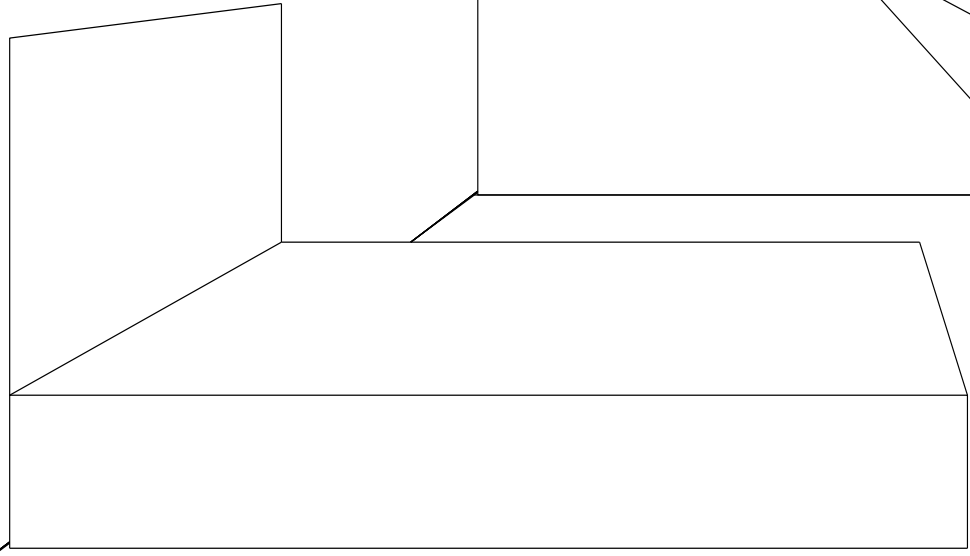
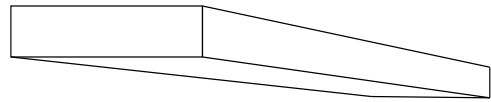

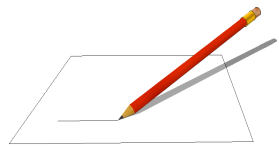

Hints: Sharp Pencil
Light Lines

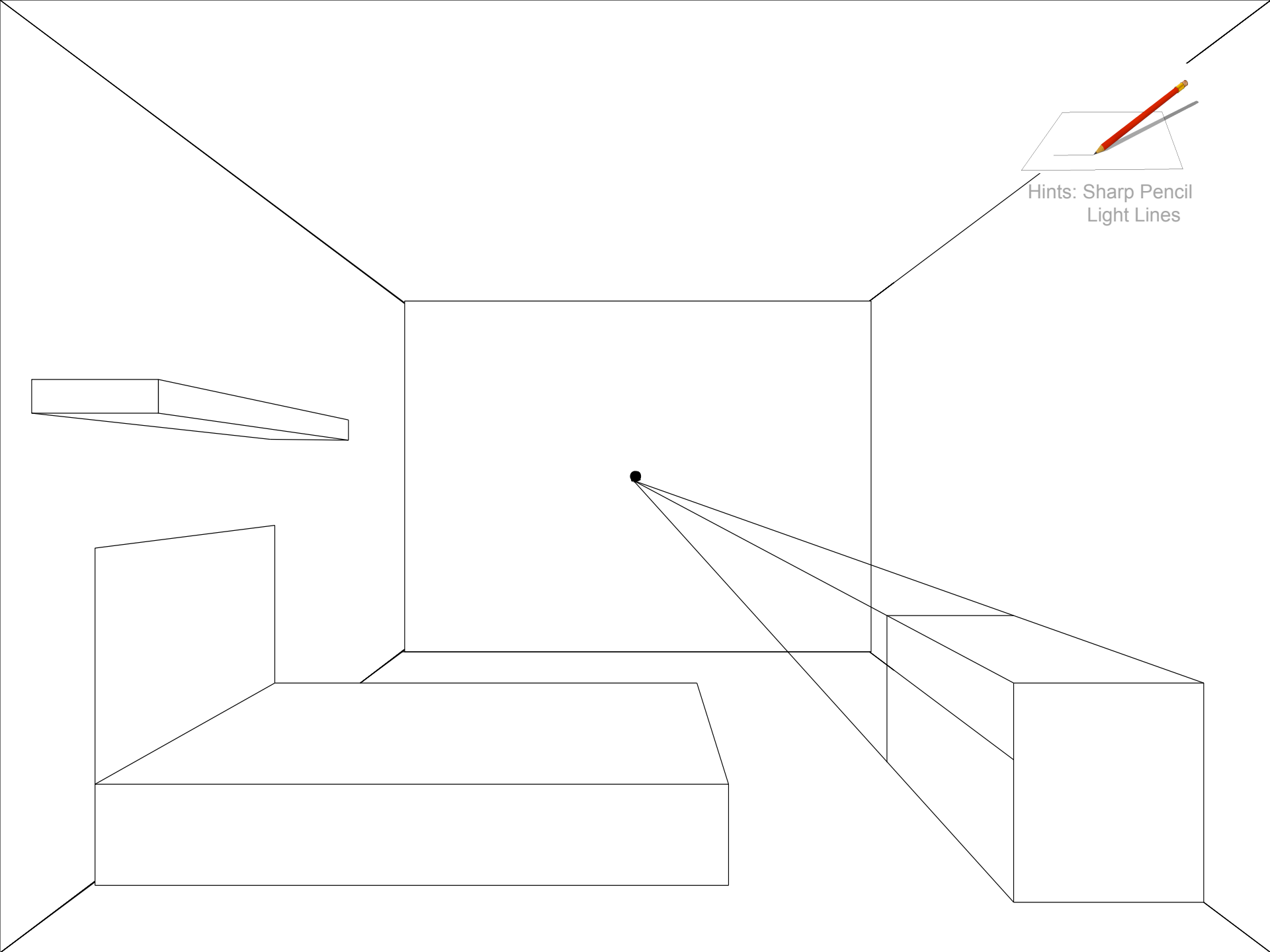
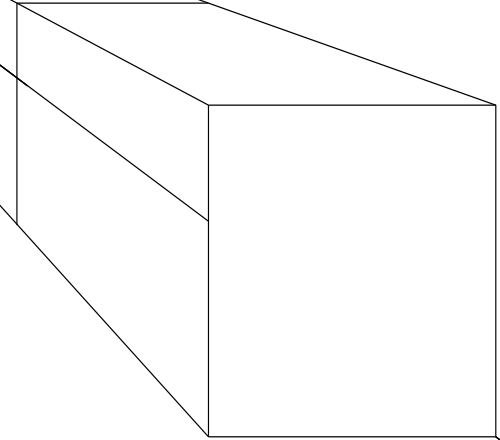
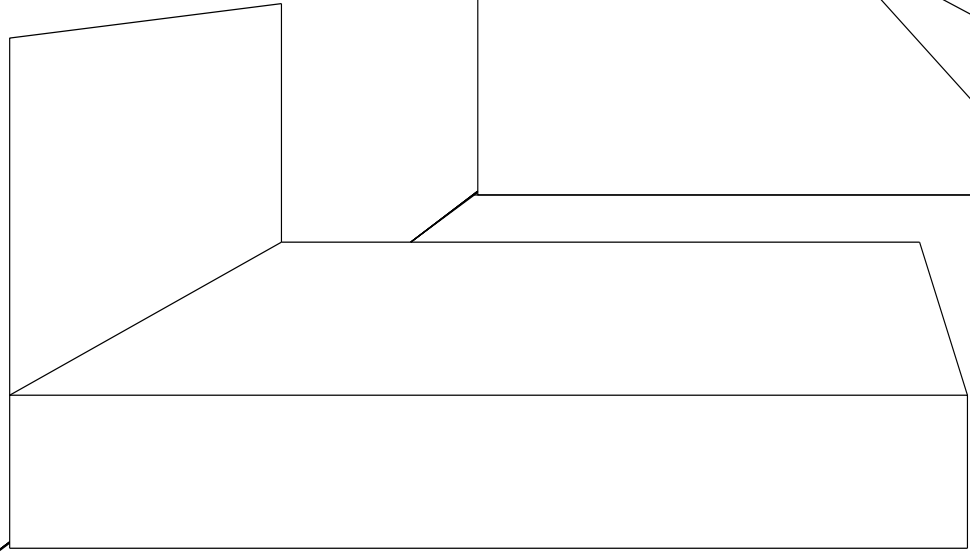
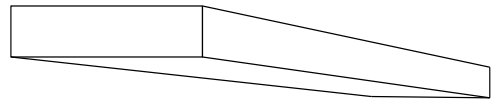

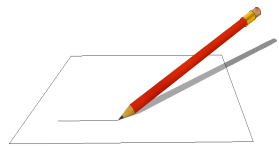

Hints: Sharp Pencil
Light Lines

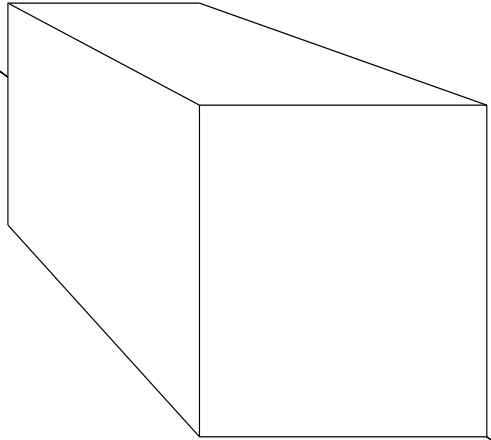
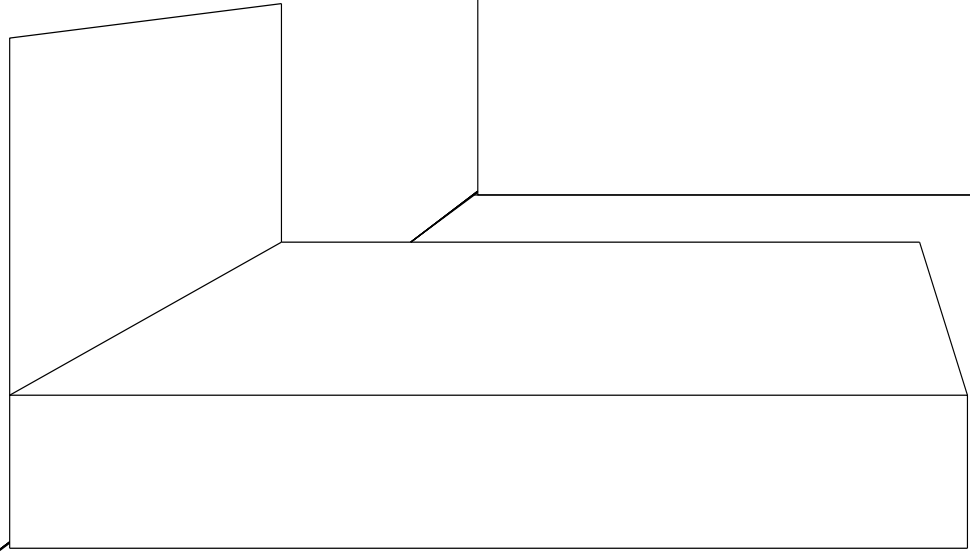
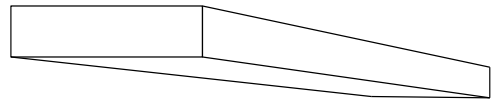

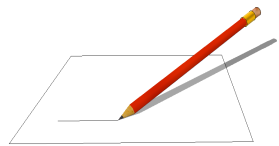

Hints: Sharp Pencil
Light Lines

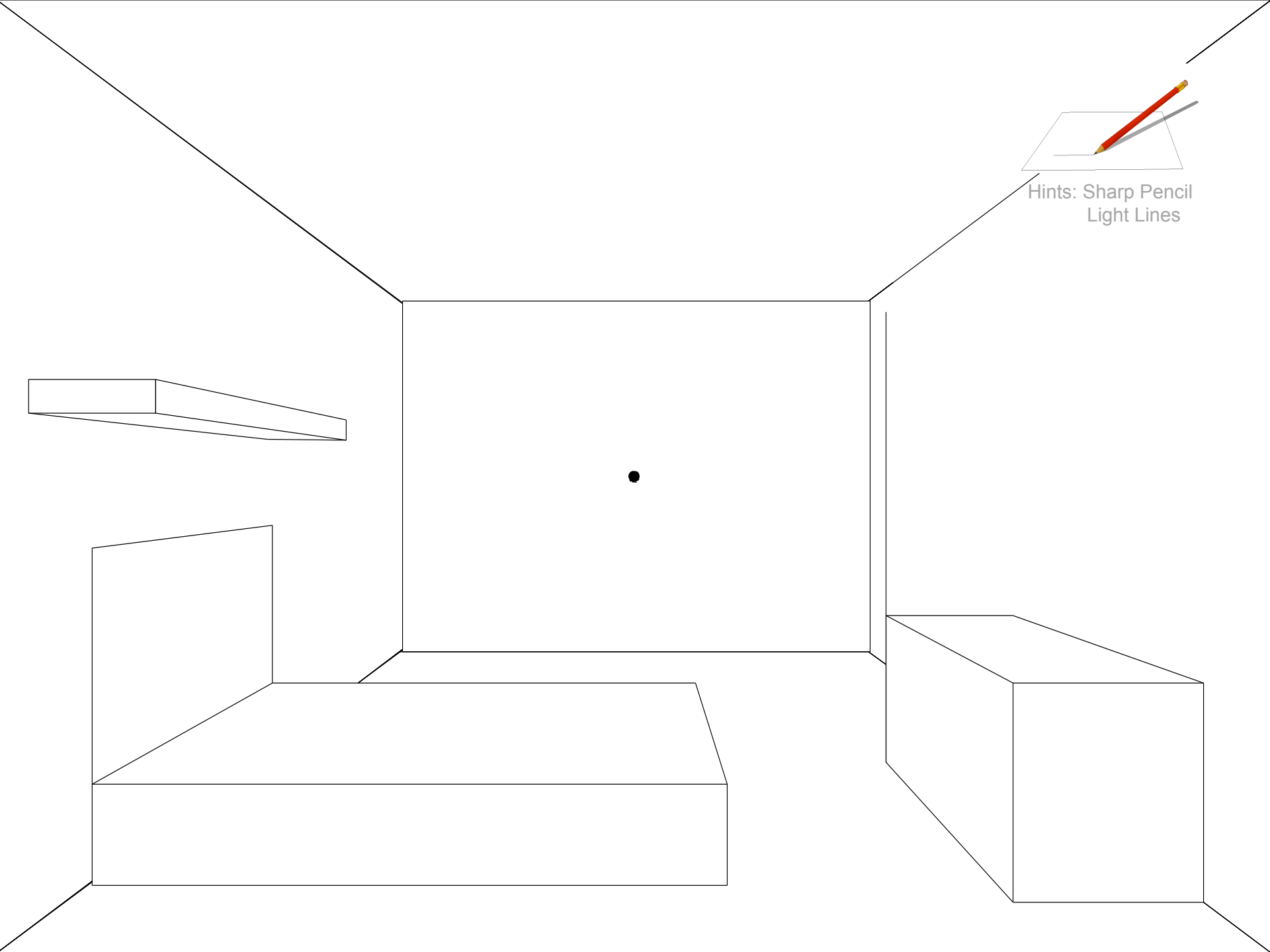

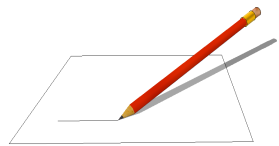

Hints: Sharp Pencil
Light Lines

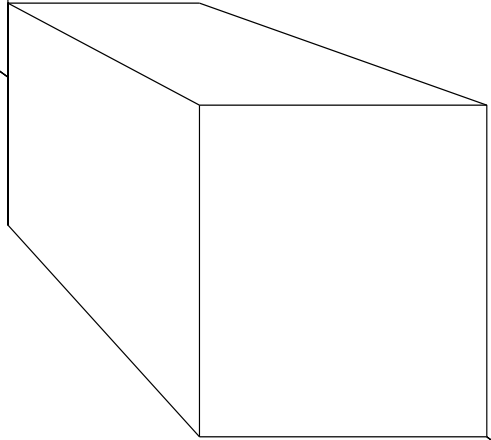
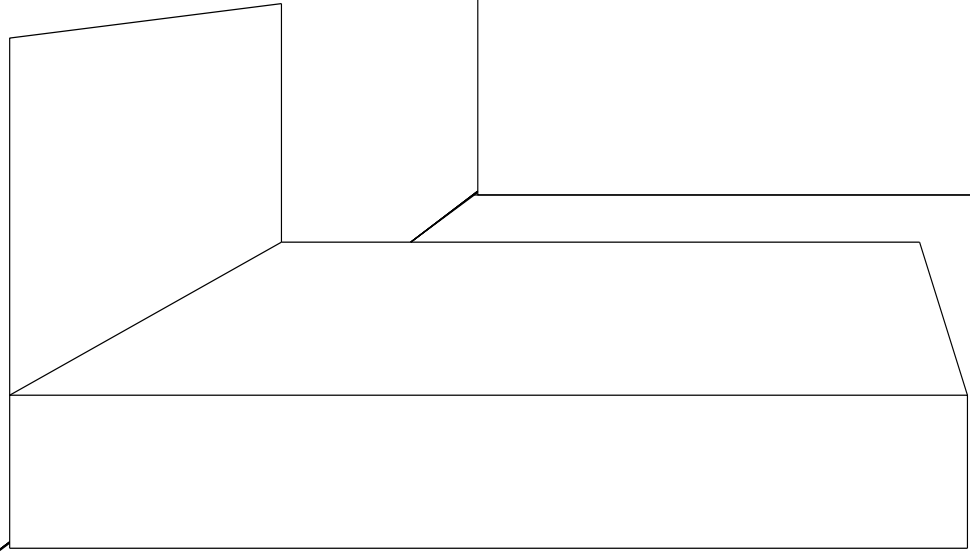
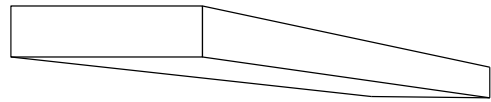

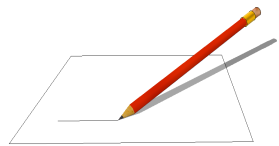

Hints: Sharp Pencil
Light Lines

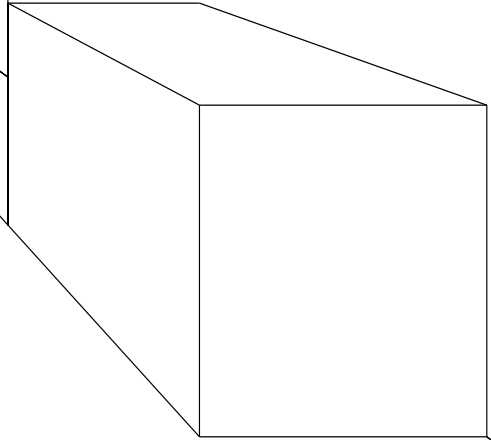
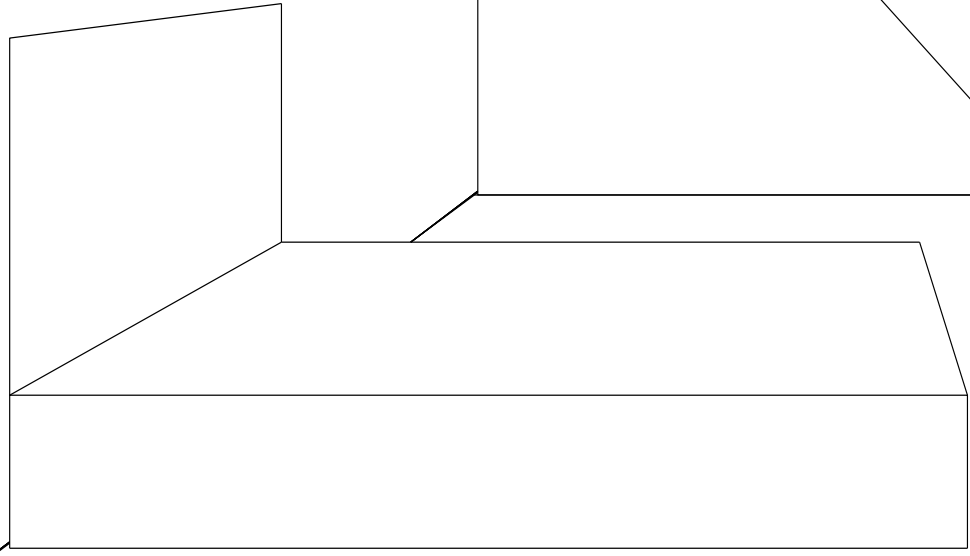
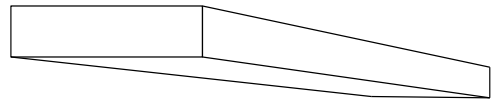

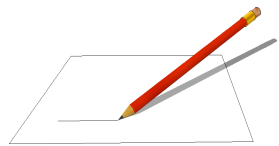

Hints: Sharp Pencil
Light Lines

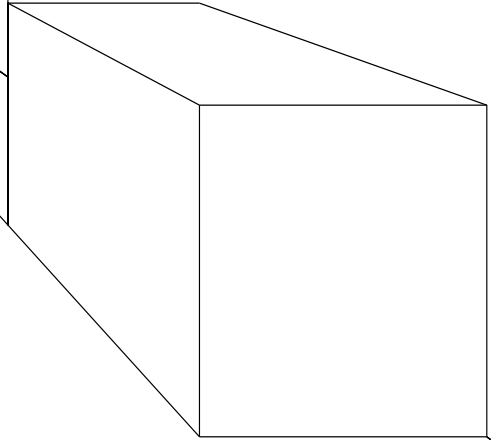
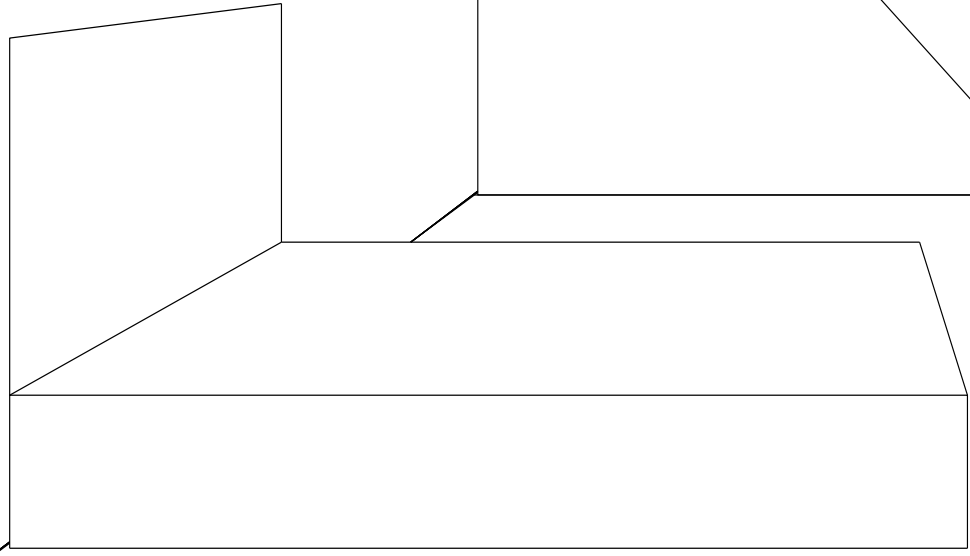
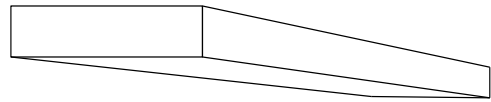

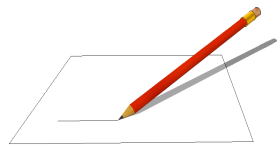

Hints: Sharp Pencil
Light Lines

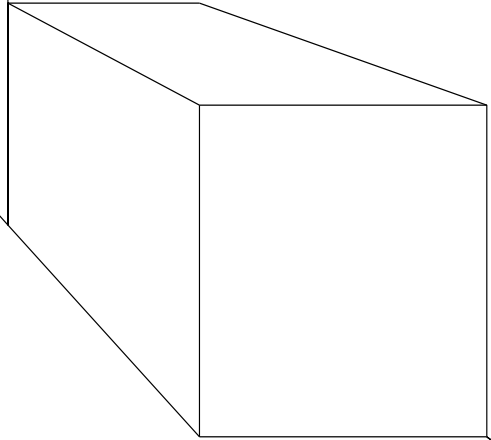
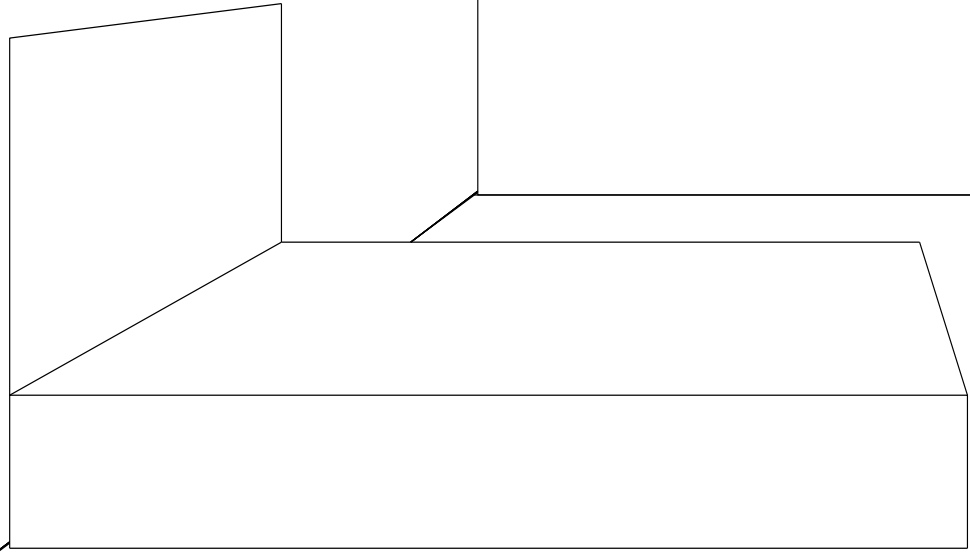
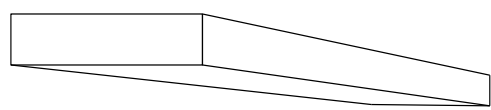

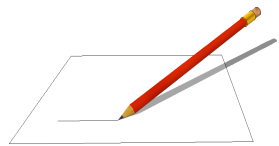

Hints: Sharp Pencil
Light Lines

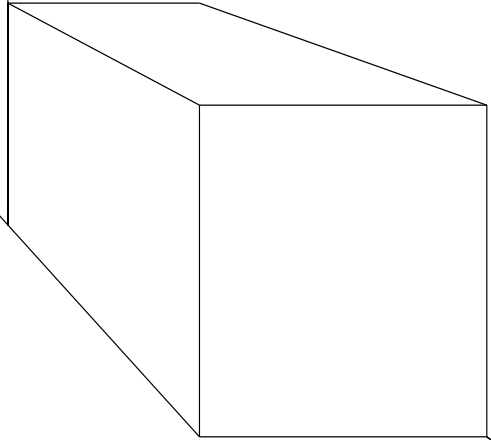
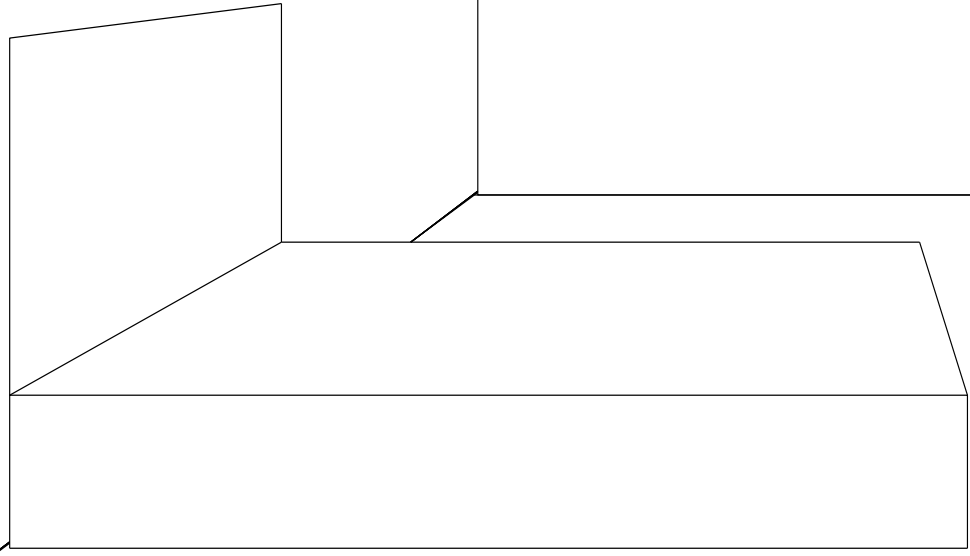
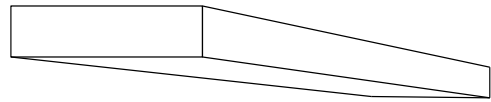

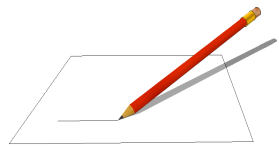

Hints: Sharp Pencil
Light Lines

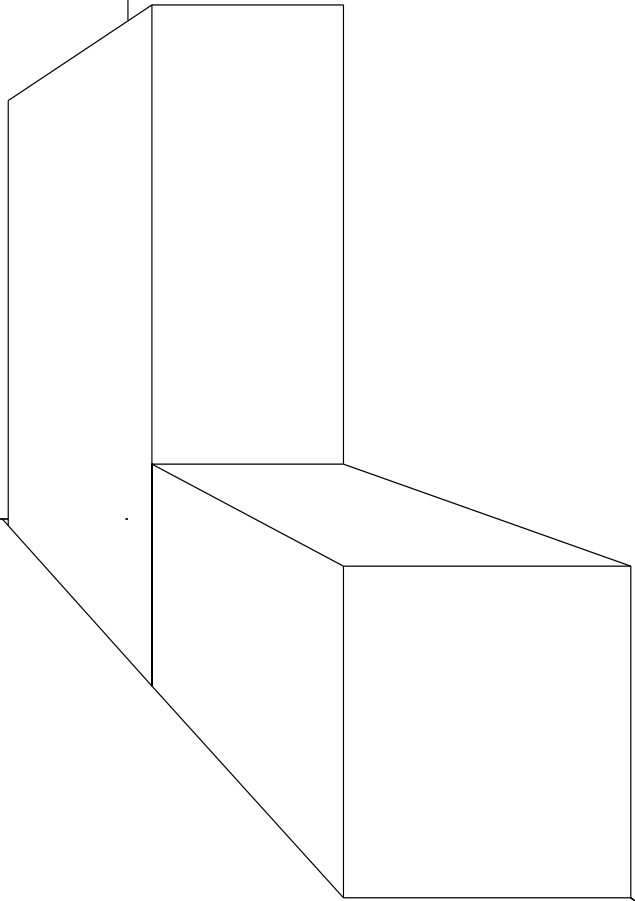
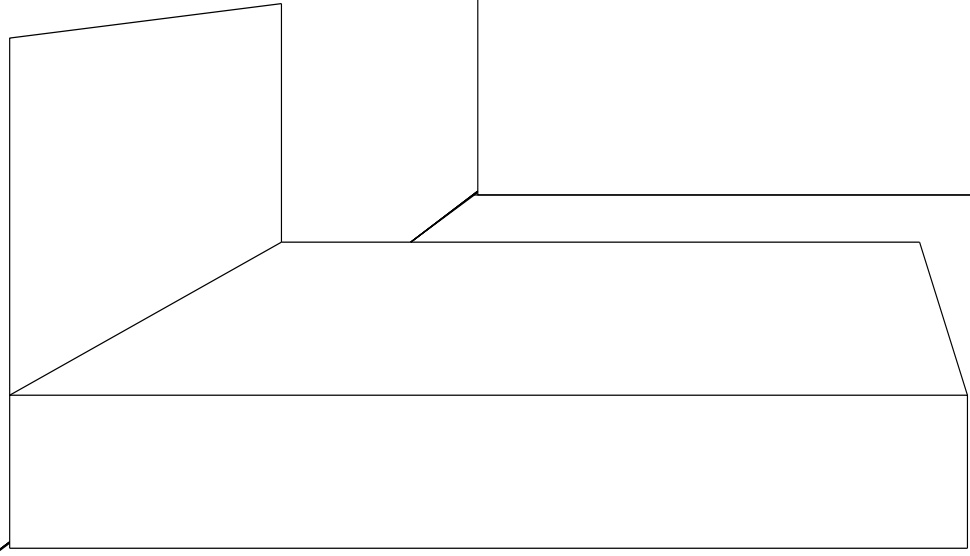
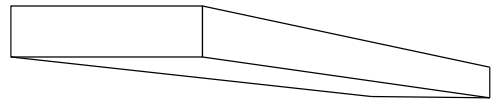

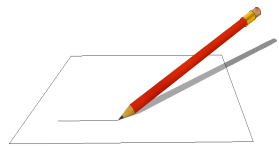

Hints: Sharp Pencil
Light Lines

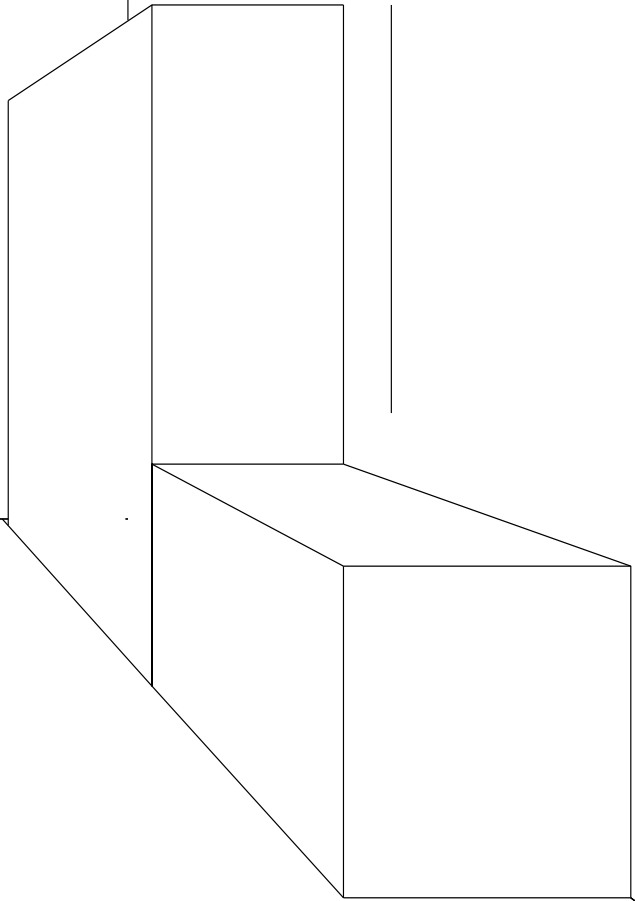
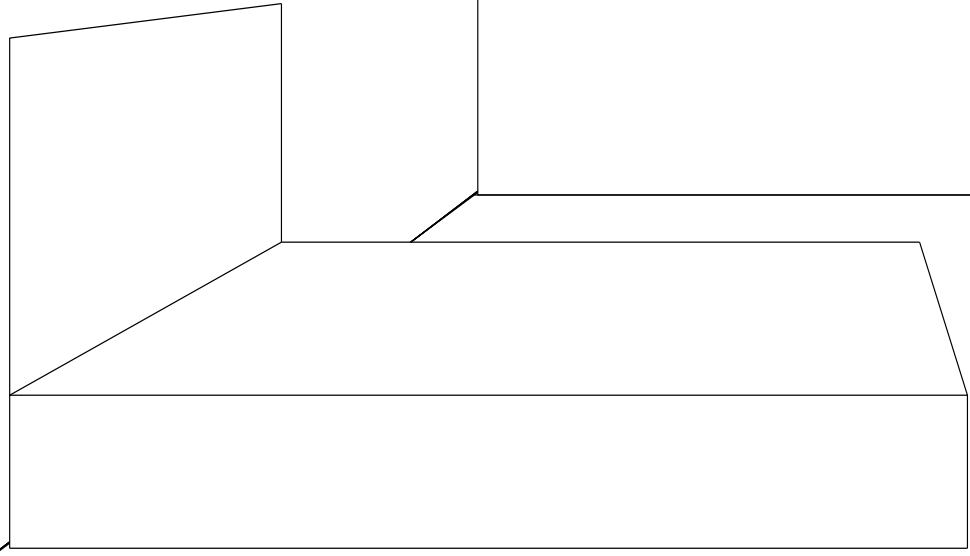
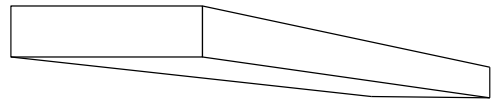

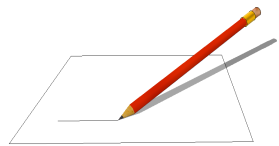

Hints: Sharp Pencil
Light Lines

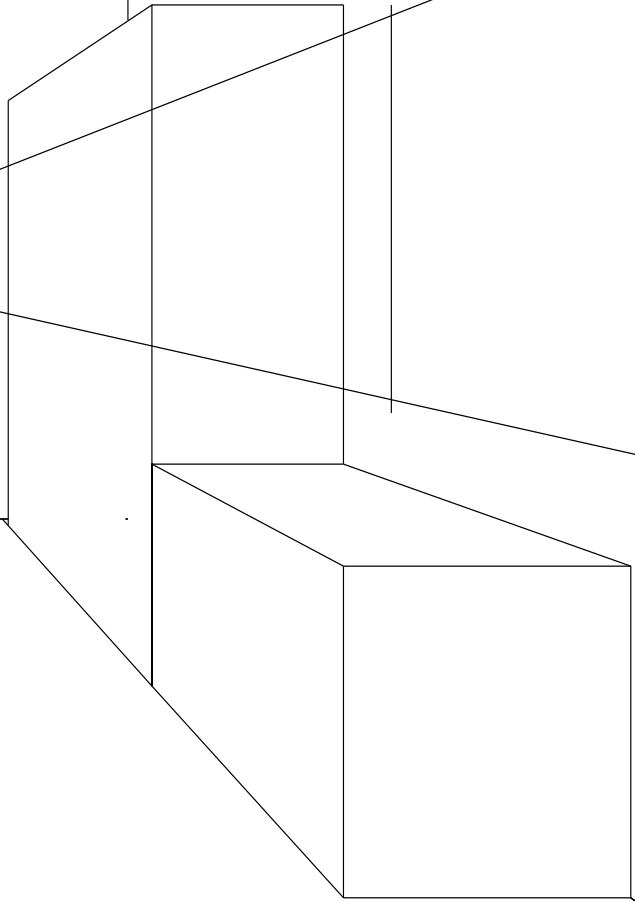
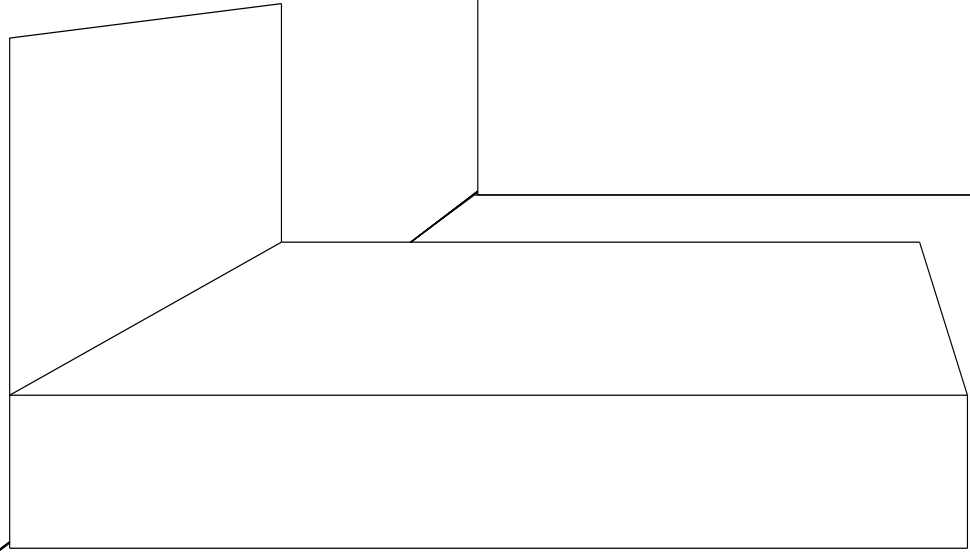
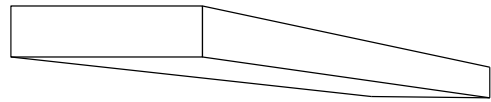

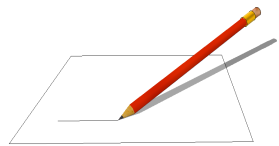

Hints: Sharp Pencil
Light Lines

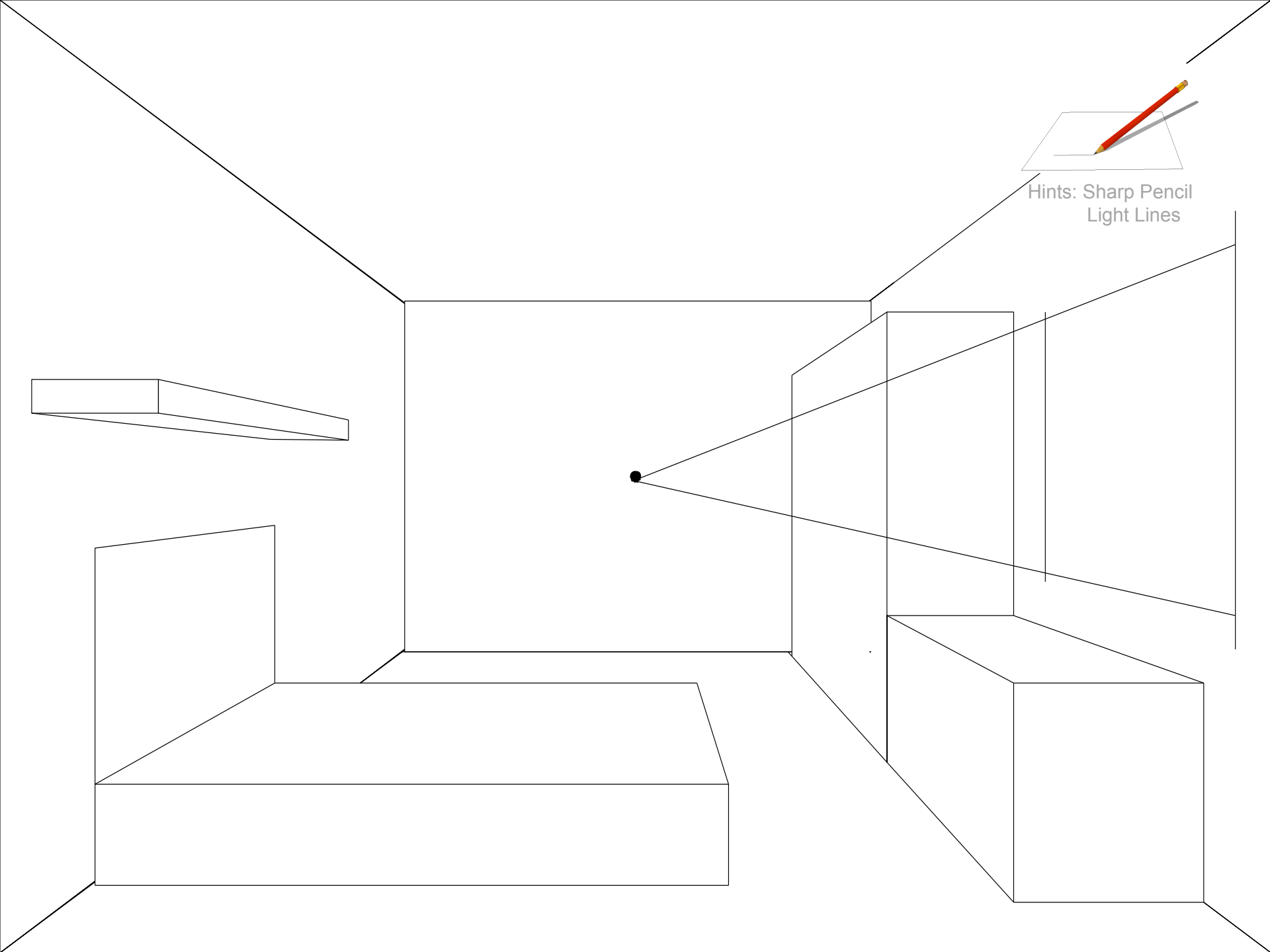

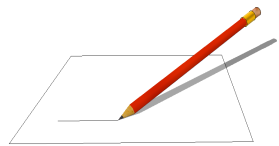

Hints: Sharp Pencil
Light Lines

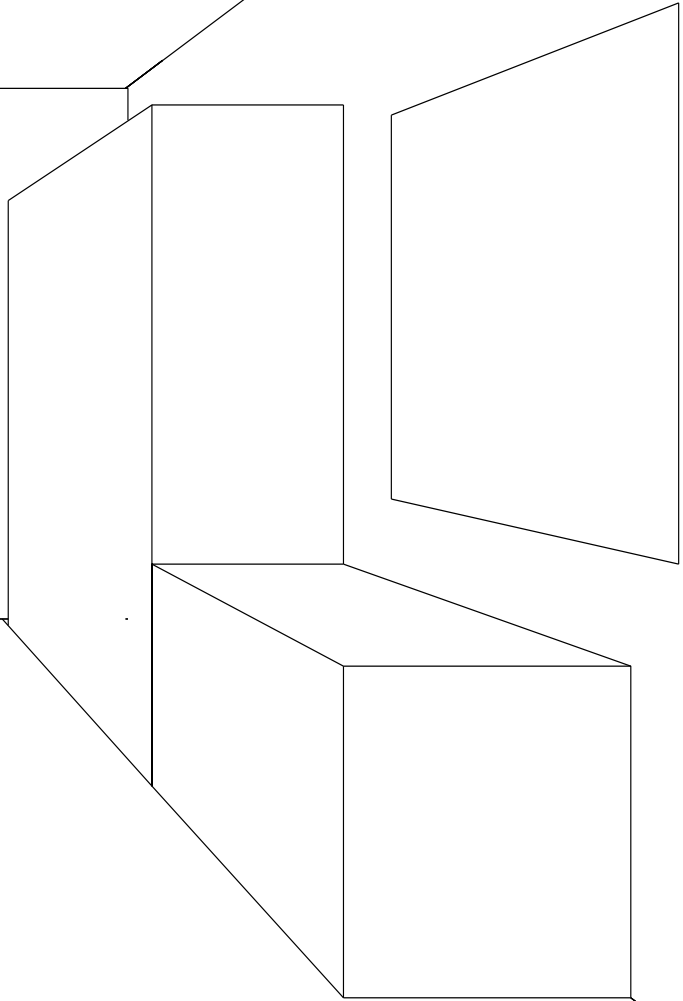
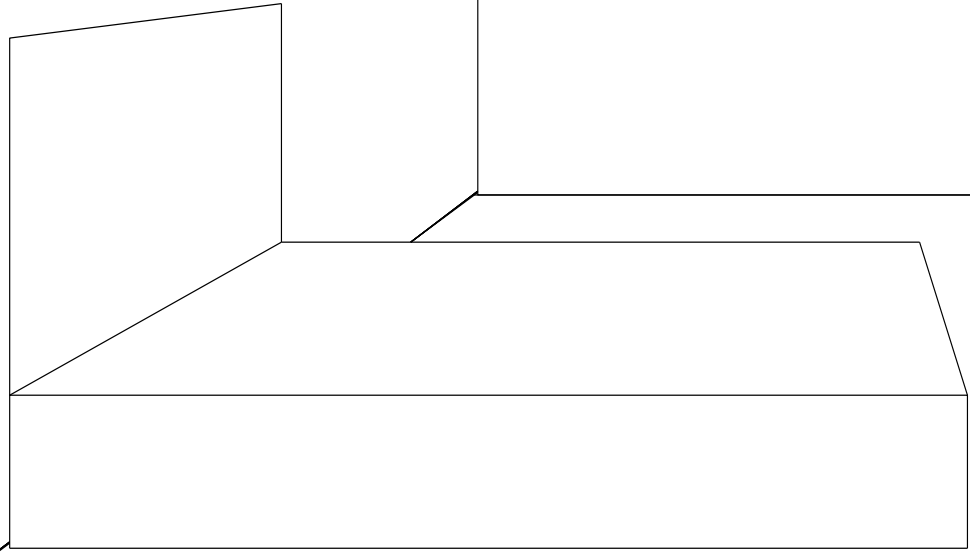
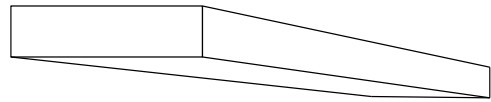

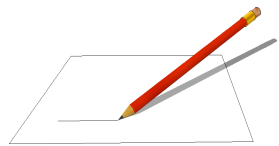

Hints: Sharp Pencil
Light Lines

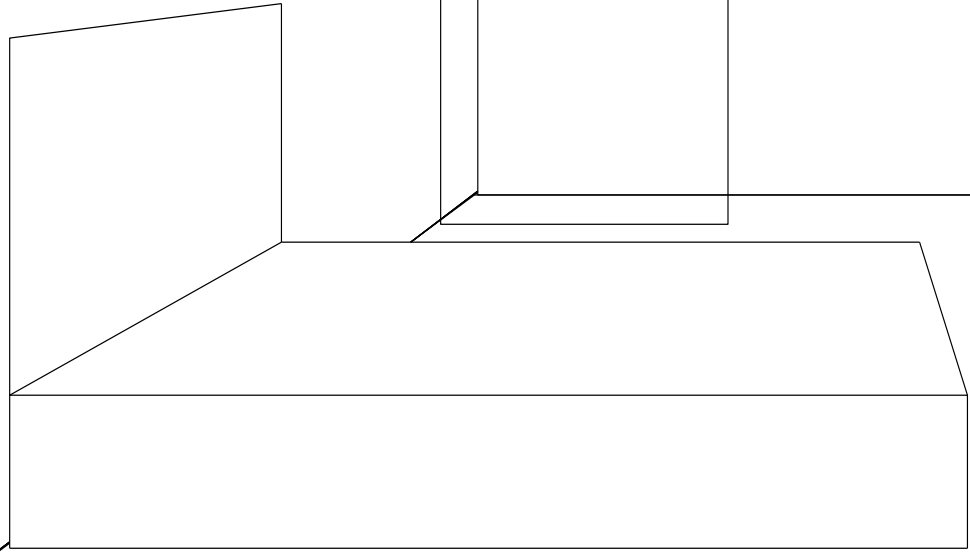
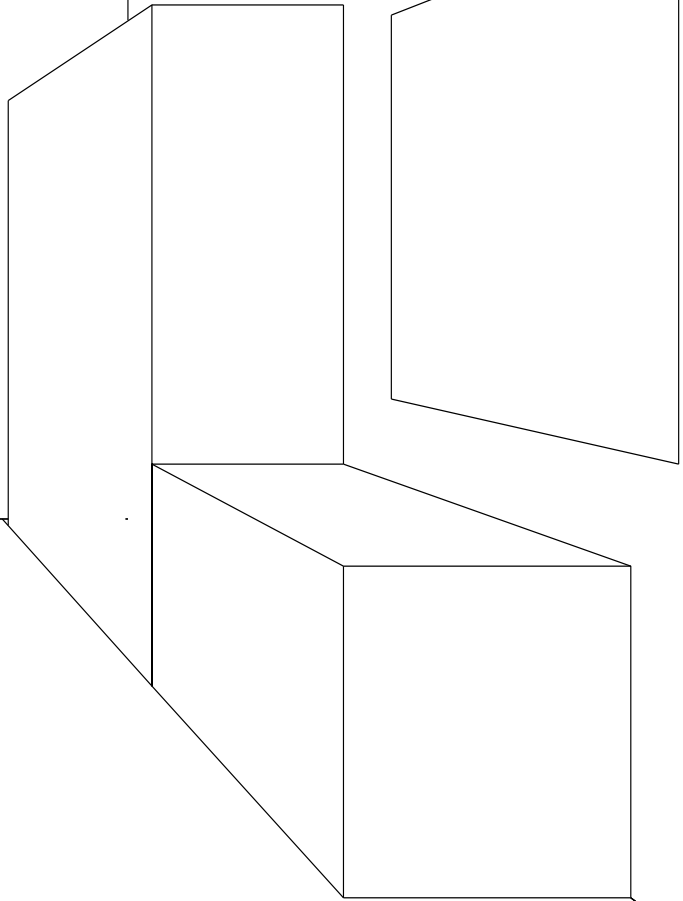
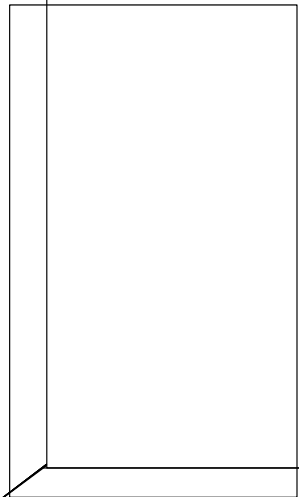
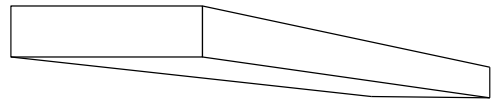

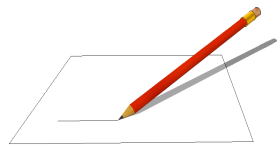

Hints: Sharp Pencil
Light Lines

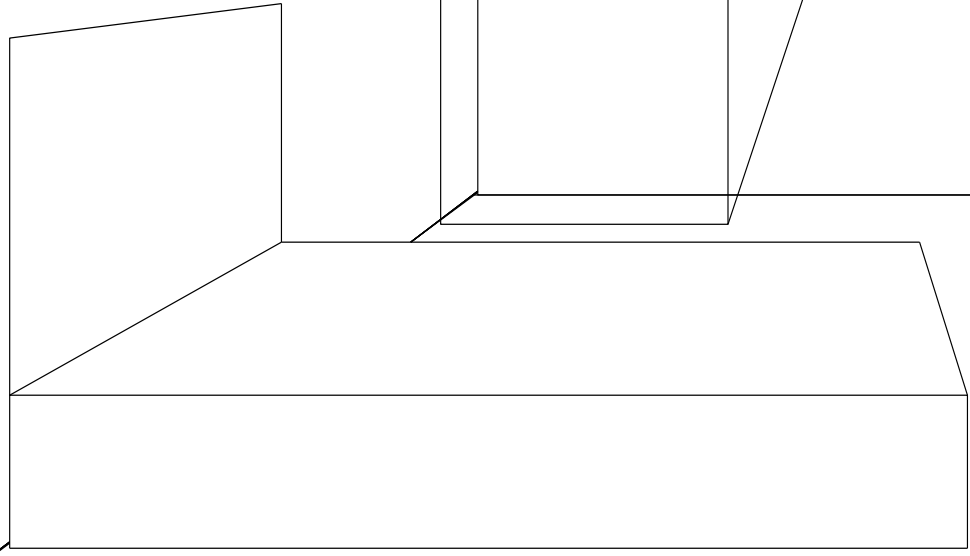
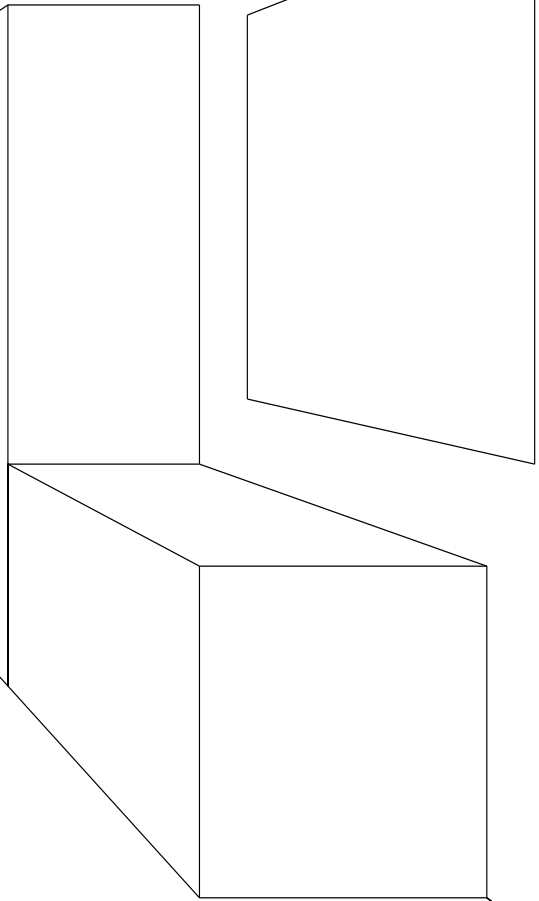
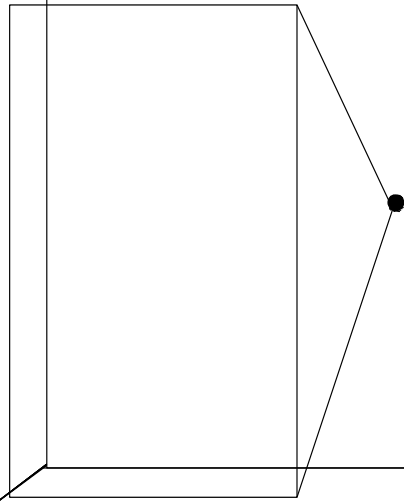
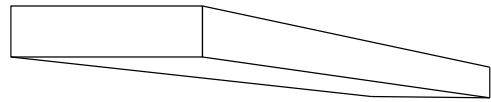

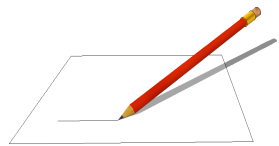

Hints: Sharp Pencil
Light Lines

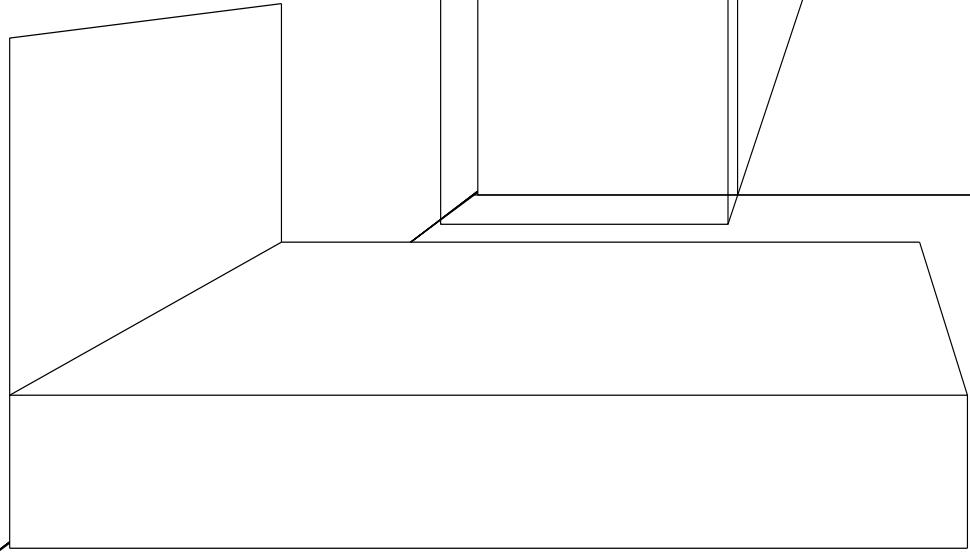
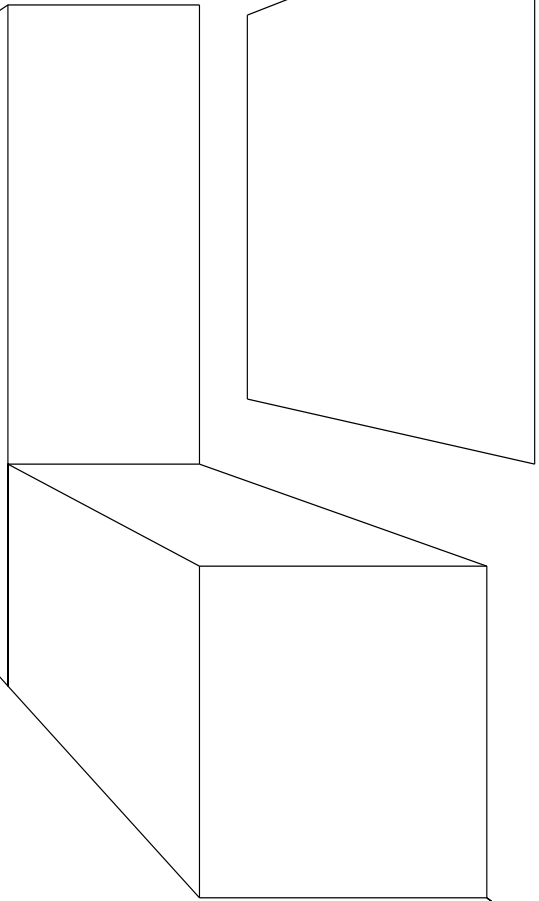
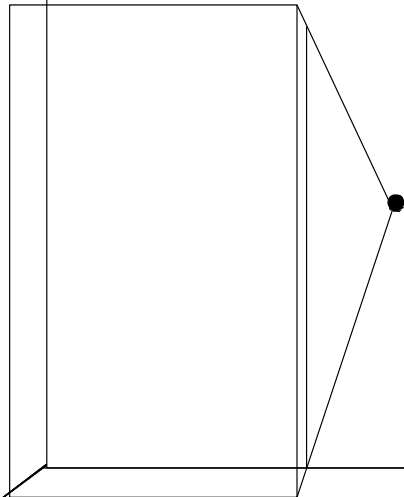
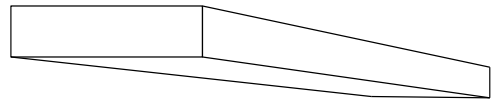

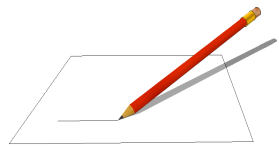

Hints: Sharp Pencil
Light Lines

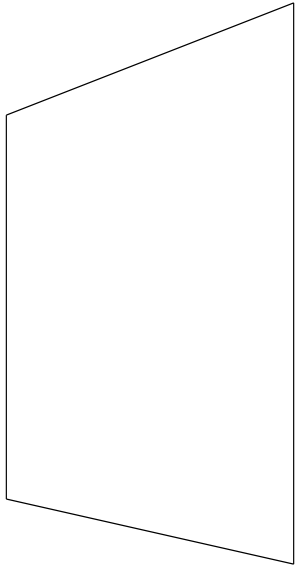
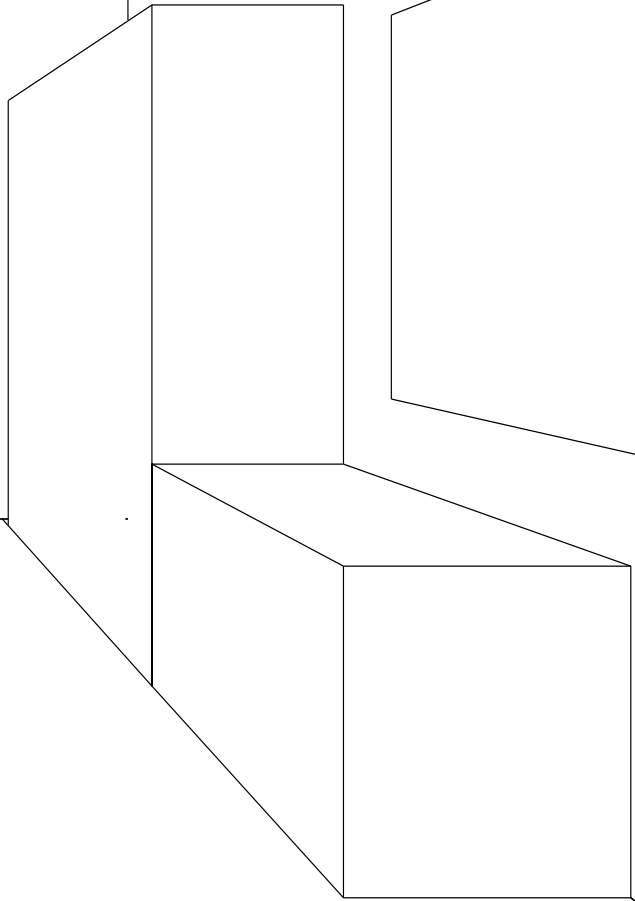
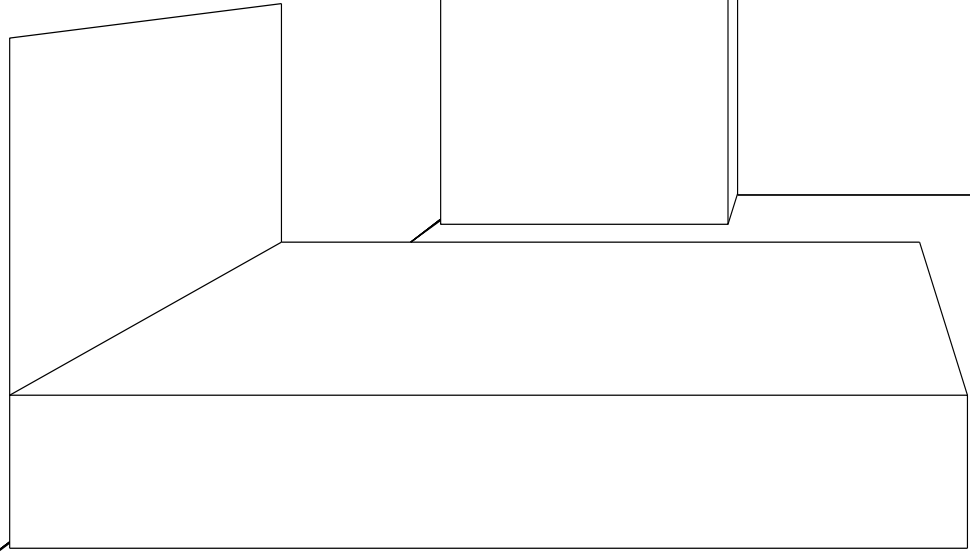
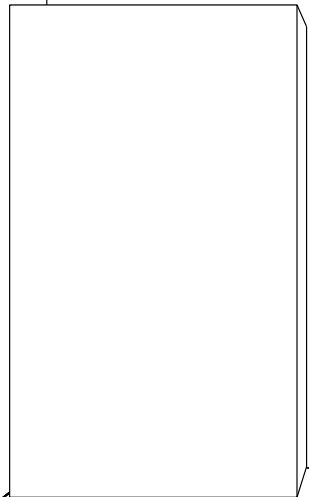
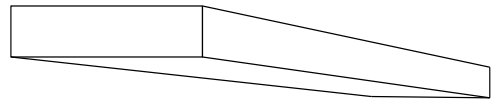

Complete the rest of the drawing adding your own details and any extra visual pieces you wish, to **show your independent skills**. The more skills you show the more marks you will get for your drawing



Extension Activity

Complete the rest of the drawing adding your own details and any extra visual pieces you wish, to **show your independent skills**. The more skills you show the more marks you will get for your drawing

